



# SUPERWINCH

*“Leader in Global Winch Solutions”*

**Product  
Guide**

**2014  
2015**



**Designed, Engineered, Tested and Built by**



# SUPERWINCH®

## RECOVERY

8,500 lbs - 18,000 lbs (3856 kg - 8165 kg) Capacity

Pages  
6-37

## UTILITY

2,000 lbs - 5,000 lbs (907 kg - 2286 kg) Capacity

Pages  
38-45

## ATV

2,000 lbs - 4,500 lbs (907 kg - 2040 kg) Capacity

Pages  
46-51

## INDUSTRIAL

Hydraulic, Commercial, AC, Power Drives

Pages  
52-65

## MOUNTS

Mounting Systems for ATV, Jeeps, Pickups

Pages  
66-70

## ACCESSORIES

Winching Gear, Replacement Parts and Wireless Remote

Pages  
70-78

# SUPERWINCH® **Choose the right Winch**

## How to choose a Vehicle Recovery Winch:

1. Find needed winch load capacity: vehicle weight (loaded with gear) multiply by 1.5
2. Match capacity with a winch range that meets your needs for speed, durability and price.
3. Find a Superwinch dealer at [www.superwinch.com](http://www.superwinch.com) for assistance.



Talon Premium Winch Series - **Premium**  
9,500 - 18,000 lbs Capacity  
(4309 - 8165) kgs Capacity

The Superwinch Talon is the next generation of winches and the first specially designed for synthetic rope. Our team of engineers has managed the near impossible: fast and smart and a price that won't break the bank.



Husky Winch Series - **Premium**  
8,500 - 12,000 lbs Capacity  
(3856 - 5443) kgs Capacity

The iconic Superwinch Husky is World renown for durability and reliability - tough enough to conquer the Camel Trophy. Worm style gearbox provides years of worry free pulling. The choice of *Bill Burke*. Built in the U.K.



X9 and S9000 Winch Series - **Premium**  
9,000 lbs Capacity  
(4082) kgs Capacity

The X9 and S9000 are the USA built work horses needed when it's time to get serious. Designed to be field-serviceable with as few tools as possible. These winches have proven their worth in the field time and time again.



HW and HP Hydraulic Winch Series - **Premium**  
8,000 - 45,000 lbs Capacity  
(3630 - 20412) kgs Capacity

The Superwinch line of hydraulic winches provides a continuous duty solution to any heavy duty winch requirement. They were designed with the toughest commercial/industrial applications in mind. Available in a full range of planetary and worm-gear drives with capabilities from 8,000 to 45,000 pounds. Our hydraulic winches are built to SAE J706 standards and are CE certified. Superwinch PRO Series winches conform to BS EN 14492-1 Power Driven Winches and Machinery Directive 2006/42/E. When the job is on the line, look no further than Superwinch.



**Tiger Shark Series - *The New Standard***  
 9,500 -17,500 lbs Capacity  
 (4309 - 7938) kgs Capacity

With over 40 years experience, our engineers at Superwinch built a winch that defies common trade-offs. Stainless steel, sealed solenoid and motors, safe pull and turn freespool and all at a fraction of the cost of any other quality winch.



**LP Winch Series - *Value***  
 8,500 -10,000 lbs Capacity  
 (3856 - 4536) kgs Capacity

Ahead of its time, the LP defined what an affordable winch could be. Now the standard for entry-level, this winch still stands above others thanks to continuous improvement and refinement.

## How to choose an ATV Winch:

1. Small ATVs can go with a winch rated, 1,000 - 2,500 lbs in capacity
2. Larger ATVs are wise to go with a, 3,000 - 3,500 lbs in capacity
3. UTV and Side by Sides require, 3,500 - 4,500 lbs in capacity
4. Find a Superwinch dealer at [www.superwinch.com](http://www.superwinch.com) for assistance.



**Terra Winch Series - *Premium***  
 2,500 - 4,500 lbs Capacity  
 (1134 - 2041) kgs Capacity

Designed with the toughest terrain in mind, this line of sealed winches stand out with wider metal gears, larger, more efficient motors and beefed up drums for synthetic rope.



**Superwinch LT Series - *Value***  
 2,000 - 4,000 lbs Capacity  
 (907 - 1814) kgs Capacity

The trusty LT Series from Superwinch is the value workhorse. With years of use in the field, the LT brings a low entry price plus confidence to get the job done.



**Winch-In-A-Bag™ - *Versatile***  
 2,000 - 2,500 lbs Capacity  
 (907 - 1134) kgs Capacity

Whether rescuing yourself or others from danger, unloading your boat, off roading with your 4-wheel drive vehicle, ATV, motorcycle, dirt bike or snowmobile, or on the job site pulling a load closer to your truck, this winch is handy and ready.

## How to choose a Trailer / Utility Winch:

1. Find your needed capacity: vehicle weight (loaded with gear) and multiply by 1.5x
2. Match capacity with a winch range that meets your needs for speed, durability and price.
3. Find a Superwinch dealer at [www.superwinch.com](http://www.superwinch.com) for assistance.



**Superwinch S Series - *Premium***  
 3,500 - 5,000 lbs Capacity  
 (1588 - 2268) kgs Capacity

The Iconic S Series is the most popular performance trailer winch on the market. With race - proven reliability, S Series winches are the *Racers's Choice*. Available with wire rope or synthetic rope. Built in the USA.



**Superwinch GP Series - *Premium***  
 3,000 lbs Capacity  
 (1588) kgs Capacity

The trusty GP Series from Superwinch is the premium workhorse providing impressive pulls with quality solenoids for a winch you're going to love. Built in the USA. (to be discontinued, 2014)



**Superwinch X Series - *Industry Standard***  
 2,000 - 4,000 lbs Capacity  
 (907 - 1814) kgs Capacity

Compact and stylish, the X line is as popular today as ever. A rugged gearbox and simple construction make these winches an economical and reliable choice. Built in the USA.



**LT / UT Series - *Value***  
 2,000 - 3,000 lbs Capacity  
 (907 - 1361) kgs Capacity

The LT and UT winches are your best choice for compact, quiet, all-purpose winching – ideal for those needing a smaller, durable tool with brand-name reliability and function. Full metal planetary gear train provides strong yet quiet operation. Additional features include dynamic braking, circuit breaker protection and low amp. system draw, at a surprisingly affordable price.



# TALON EXXTREME 12.5

NO COMPROMISE - OFF ROAD / TROPHY / ROCK CRAWLING



VITLO BEZ KOMPROMISA! AKA "The winch without compromise!"  
Born & Built in Croatia OFF-ROAD competition events from around the world, *Where only the best survive.*



RALLYE EXXTREME 12.5  
p/n 61612901



Built in Croatia

- Dual Talon 6.0 HP (4.4 kW) sealed motors that conform to the prestigious, IP67 rating and draws only 140 amps combined at no load. Winch is coated with high gloss silver finish.
- The Talon 148:1 ratio 2-stage planetary and 2-stage spur gearbox is ultra durable and takes off-road punishment with ease. Our innovative "Dual-Stop" 100% Load-holding brake design provides zero drag on cable in and is located inside the gearbox away from the drum to eliminate damaging brake heat transfer to the synthetic rope.
- Gear Housing (left) and drum support (right) are made from high strength billet aluminum alloy EN 66802 - AlMgSi1 with clear anodized finish for durability. Gears are made from Alloy Carbon steel 20MnCr5, heat treated, tempered and hardened to 62HRc rating.
- Drum is positioned between 2 oversized sealed bearings. Drum flanges are made from 10mm steel and then precision machined to 8mm on each side to resist the unique loading characteristics of synthetic rope. Drive shaft is heat treated, tempered and hardened to withstand high speed and torque.
- Rallye model include dual Talon VS4 IP67 rated solenoids housed in a stainless steel control box, ergo shaped IP67 rated hand-held remote with coiled cord, anodized aluminum hawse, yellow heavy duty latched half-link hook and a dual set of motor leads.
- Trophy model is designed for the hard-core competition vehicle. Solenoids, remote, hawse, hook and motor leads must be supplied by the vehicle builder.

# SUPERWINCH®

## Technical Data EXXTREME



	RALLYE	TROPHY
Model	XXTREME 12.5	XXTREME 12.5
Part Number	61612901	61612900
Voltage	12 VDC*	12 VDC*
Rated Pull Lbs (kg)	12,500 (5669)	
Motor hp (kW)	Dual 6hp (4.44)	
Gearing	3-Stage Spur/2-Stage Planetary	
Gear Ratio	74:1	
Solenoid	Dual VS4	N/A**
Freespool	Ergonomic Pull and Turn	
Brake	Automatic 100% Load Holding (outside of drum)	
Rope Length ' (m)	N/A	
Rope Dia " (mm)	N/A	
Hook	Heavy Duty / Half-Link / Latch	
Fairlead/Hawse	luminum Hawse	OPTIONAL
Remote Control	Exclusive Talon Ergo	OPTIONAL
Installed lbs (kg)	120 (54) No Rope	
Shipping lbs (kg)	135 (61.2)	
Warranty	Limited Lifetime	

Performance		
No Load	Amps	140
	Line Speed FPM (MPM)	72 (21.9)
	Increase over Talon	116%
2,000 lb (907)	Amps	327
	Line Speed FPM (MPM)	33.5 (10.2)
	Increase over Talon	176%
2,000 lb (907)	Amps	460
	Line Speed FPM (MPM)	20 (6.2)
	Increase over Talon	145%
6,000 lb (2721)	Amps	600
	Line Speed FPM (MPM)	13 (3.96)
	Increase over Talon	130%
12,500 lb (5669)	Amps	975
	Line Speed FPM (MPM)	4 (1.21)
	Increase over Talon	145%



\*Requires dual batteries to properly operate the winch.

\*\*Superwinch recommends 2 solenoids to operate the winch.

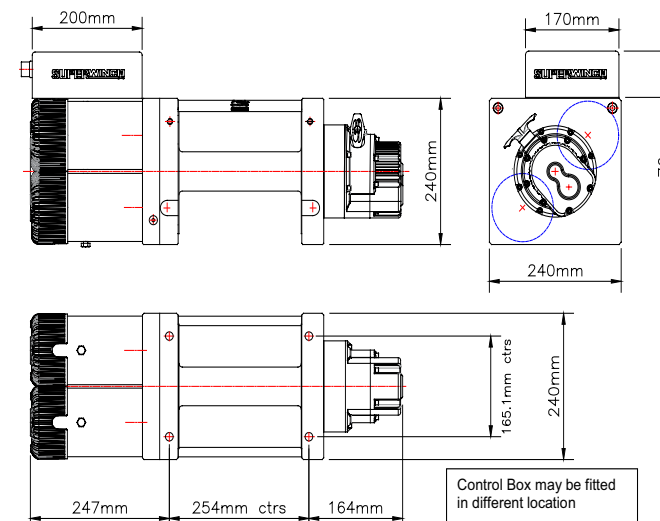



# TALON 9.5 / 12.5

VEHICLE RECOVERY / COMMERCIAL / INDUSTRIAL / OFF - ROAD



CE

**"AKA THE WINCH OF PREY"**

**Talon 12.5**  
P/N 1612200 12VDC  
P/N 1612300 24VDC



- Sealed 5.2 HP and 6.0 HP motors deliver a quick but safe 62 FPM line speed at a low 75 Amp draw. Heat sink styled motor cap maintains low temperatures under the heaviest loads.
- Innovative "Dual-Stop" 100% load-holding brake design provides zero drag on cable in. Located inside the gearbox away from the drum to eliminate heat transfer to the synthetic rope.
- Laser etched aerodynamically-shaped extruded aluminium tie bars reduce weight. Three (3) tie bar construction adds strength and structural rigidity between drum supports.
- Chrome plated aluminium ergonomic free spool knob lifts and turns effortlessly. Easily rotates in 45° increments for custom applications and "in bumper" applications.
- Covered by a Limited Lifetime Warranty, which includes an industry-first 3-year warranty on all electrical components, the absolute BEST in the INDUSTRY!

**Talon 9.5iSR**  
P/N 1695211 12VDC  
P/N 1695311 24VDC



8

# SUPERWINCH®

Advantages  
**TALON**



**Serious About Synthetic**

Superwinch believes Synthetic Rope requires a specially designed winch. Synthetic rope loads differently than wire cable, and the resulting force can be catastrophic. As proof of this belief, Superwinch designed and engineered the, *Talon performance winch series*. It is Specially designed to handle synthetic rope in 3 ways.

- Reinforced drum flange and tube.
- Brake is located away from the drum to prevent heat transfer.
- Certified Dyneema® rope is used by Superwinch.



**King of Hand Held Remotes**

Unlike any other on the market today, Superwinch Talon remote is a break-through innovation. Designed to be ergonomically correct, the remote features a tidy 15' coil cord that allows quick deployment and fast storage. The on board LED-light runs off AAA batteries to ensure adequate light where you need it most. Soft, push button control combined with LED indicators confirm the remote is sending the proper signal to keep your winching safe.



9



Advantages  
**TALON**

**SUPERWINCH**

### Serious About Solenoids

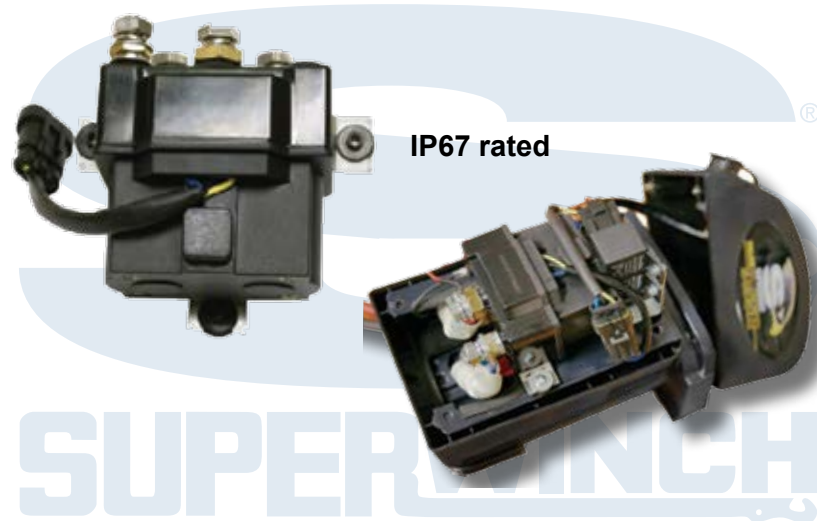

Superwinch set out to prove the Solenoid doesn't have to be a drawback. Instead, Superwinch created the VS4 and made it one of the reasons people love their Talon winches.

Most companies gloss over the Solenoid, choosing some off-the-shelf unit but not Superwinch. Superwinch added a Gore-Tex vent, allowing solenoid-busting moisture to exit while keeping the entire unit sealed.



### More seals than your local aquarium



Superwinch then goes the extra mile and motion stabilizes the solenoid in a 3 point stance. The result is a vented, stabilized, submersible solenoid that even features a sealed socket. This is the industry's best truly sealed vehicle recovery winch assembly. All seals on the entire winch from the outermost end of the high performance motor, to the 2-stage planetary and 2-stage spur gearbox to our ground breaking solenoid, meet the prestigious IP67 rating.

**SUPERWINCH**

**SUPERWINCH**

Technical Data  
**TALON**



Model	9.5	9.5SR	9.5i	9.5iSR	12.5	12.5SR	12.5i	12.5iSR
Part Number	1695200	1695201	1695210	1695211	1612200	1612201	1612210	1612211
Voltage	12 VDC	12 VDC	12 VDC	12 VDC	12 VDC	12 VDC	12 VDC	12 VDC
Rated Pull lbs (kg)	9,500 (4309)				12,500 (5670)			
Motor hp (kW)	5.2 (3.8)				6.0 (4.4)			
Gearing	2-Stage Spur/2-Stage Planetary							
Gear Ratio	148:1							
Solenoid	VS4 (Sealed Submersible Vented)							
Freespool	Ergonomic Pull and Turn							
Brake	Automatic, Load Holding, Located Outside Drum							
Rope Length ' (m)	85 (26)	80 (24.4)	85 (26)	85 (26)	85 (26)	80 (24.4)	85 (26)	85 (26)
Rope Dia " (mm)	3/8 (9.5)	3/8 (9.5)	3/8 (9.5)	3/8 (9.5)	3/8 (9.5)	3/8 (9.5)	3/8 (9.5)	3/8 (9.5)
Hook	Heavy Duty/Clevis Pinned/Latched							
Fairlead/Hawse	Fairlead	Hawse	Fairlead	Hawse	Fairlead	Hawse	Fairlead	Hawse
Remote Control	Exclusive Ergo Handheld							
Installed lbs (kg)	90 (41)	65 (30)	92 (42)	67 (30)	95 (43)	68 (31)	95 (43)	70 (31)
Shipping lbs (kg)	103 (47)	78 (35)	105 (48)	80 (36)	108 (48)	81 (37)	108 (48)	83 (37)
Warranty	Limited Lifetime Plus 3-Year Electronic							
UPC	022705169127	022705169134	022705169141	022705169158	022705169004	022705169011	022705169028	022705169035
<b>Performance</b>	<b>9.5</b>	<b>9.5SR</b>	<b>9.5i</b>	<b>9.5iSR</b>	<b>12.5</b>	<b>12.5SR</b>	<b>12.5i</b>	<b>12.5iSR</b>
No Load	Amps				75			
	Line Speed				62 (18.9)			
	fpm (mpm)							
At Load	Amps				430			
	Line Speed				530			
	fpm (mpm)				3.25 (0.99)			
<b>Alternate Versions</b>	<b>9.5</b>	<b>9.5SR</b>	<b>9.5i</b>	<b>9.5iSR</b>	<b>12.5</b>	<b>12.5SR</b>	<b>12.5i</b>	<b>12.5iSR</b>
24VDC Versions:	1695300	1695301	1695310	1695311	1612300	1612301	1612310	1612311
No Rope 12VDC	1695202		1695212		1612202		1612212	
No Rope 24 VDC	1695302		1695312		1612302		1612312	

Mounting Bolt Pattern: 10" x 4.5" (254mm x 114.3mm)

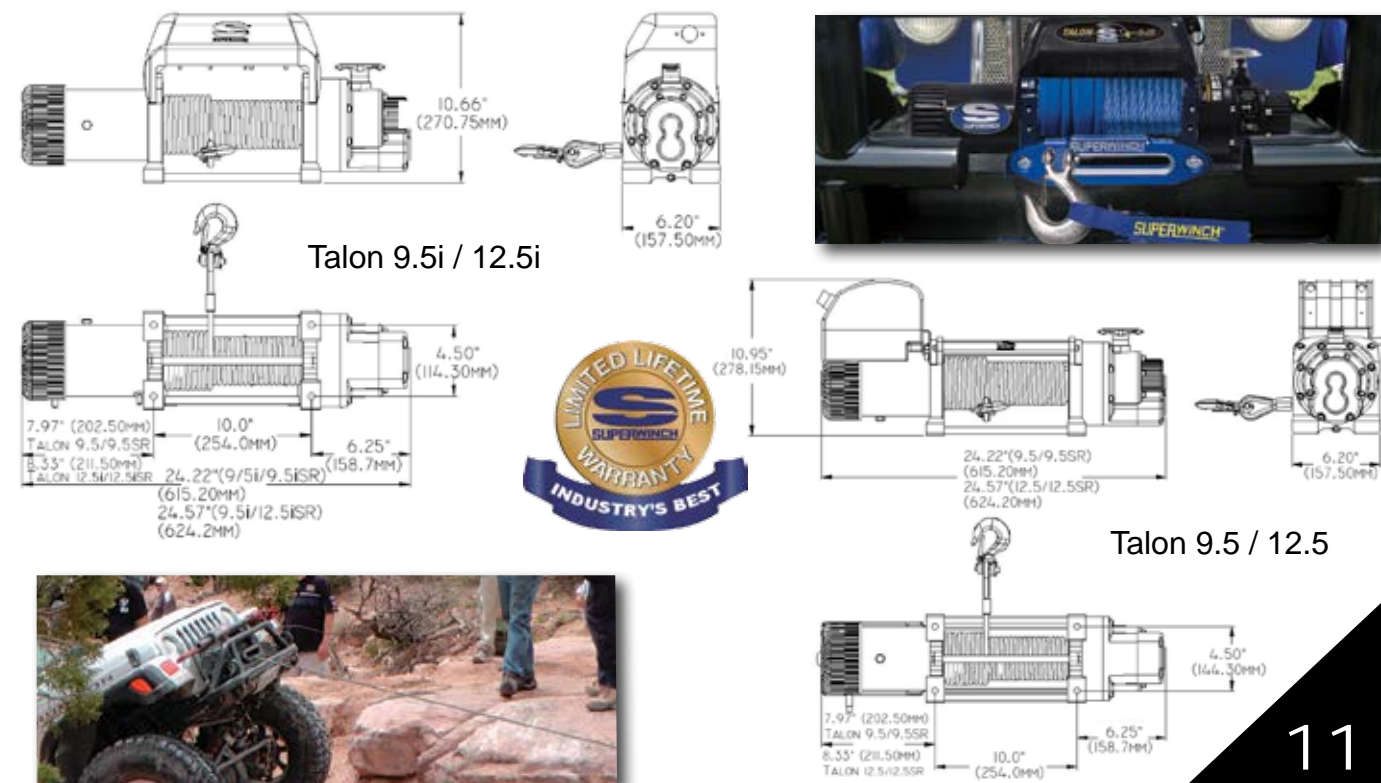



# TALON ROCK 9.8 / 12.8

VEHICLE RECOVERY / OFF ROAD / ROCK CRAWLER / TROPHY



“What is your secret” - That’s what everyone will be asking out on the trail. How can you pull at max power and get back on the ride so fast? The answer is your Superwinch Talon Rock. With up to 12,800 lbs of pulling power on 50’ of rope, you’ll be pulling in the “Power Zone” - the first two layers on the drum. Higher layers rob your winch of power - with the Talon Rock you won’t need to spool out extra rope to access it.

**Talon Rock 9.8**  
P/N 1698201 12VDC  
P/N 1698301 24VDC



- 9,800 to 12,800 lbs of pulling power in a small lightweight package!
- Weighs 28 lbs less with Dyneema™ synthetic rope
- 4” narrower for small modified competition vehicles
- Freespool knob rotates in 45° increments for custom applications
- Industrial grade, over-sized, safety yellow latched hook
- 3 solenoid box installation options (*Offset, Center-line and Competition*)

**Talon Rock 12.8**  
P/N 1612221



Superwinch synthetic ropes are genuine AmSteel-Blue™ with Samthane™, a special coating to help resist abrasion. The raw material in AmSteel-Blue® is made from genuine Dyneema® SK-75.

# SUPERWINCH®

## Technical Data TALON ROCK



### MOUNTING OPTIONS



**Offset** - solenoid over motor, as shipped



**Center-line** - solenoid over drum, kit included



**Competition** - solenoid box remotely mounted, kit included

Model	98	12.8	
Part Number	1698201	1612221	
Voltage	12 VDC	12 VDC	
Rated Pull lbs (kg)	9,800 (4445)	12,800 (5806)	
Motor hp (kW)	5.2 (3.8)	6.0 (4.44)	
Gearing	2-Stage Spur / 2-Stage Planetary		
Gear Ratio	148:1		
Solenoid	VS4 Solenoid		
Freespool	Ergonomic Pull and Turn		
Brake	Automatic, Load Holding (outside the drum)		
Rope Length ' (m)	50 (15.2)		
Rope Dia " (mm)	3/8 (9.5)		
Hook	Heavy Duty / Half-Link / Latched		
Fairlead/Hawse	Hawse		
Remote Control	15' Ergo Remote		
Weight Installed lbs (kg)	62 (28)	64 (29)	
Weight Shipping lbs (kg)	75 (34)	77 (34.9)	
Warranty	Limited Lifetime Warranty - 3 Year Electrical		
UPC	022705169196	022705169219	
Performance	98	12.8	
No Load	Amps	75	
	Line Speed fpm (mpm)	62 (18.9)	
At Load	Amps	445	650
	Line Speed fpm (mpm)	4.8 (1.46)	2.75 (.84)
Alternate Version:	Rock 98 (24VDC)		
Part Number:	1698301		

Mounting bolt pattern is 6" x 4.5" (152.4mm x 114.3mm)

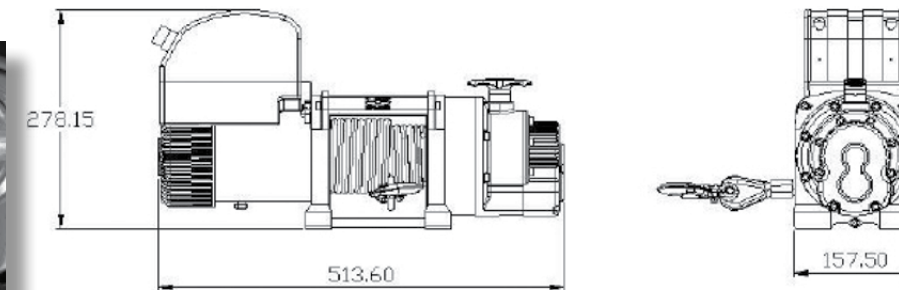

Talon Rock 98 / 12.8

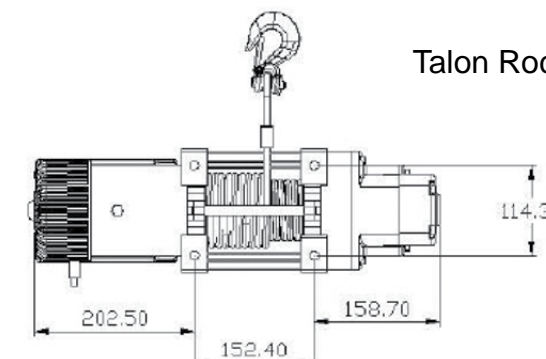



# TALON 14 & 18

VEHICLE RECOVERY / OFF ROAD / TRUCK / TRAILER



Speed and power make our tough Heavy - Duty Large Chassis Talon Series winches ideal for recovery and Super - Duty applications. Available in 14,000 lbs and 18,000 lbs with either steel or synthetic ropes.



Talor 18.0  
P/N 1618200 12VDC  
P/N 1618300 24VDC

CE



Talor 14.0 SR  
P/N 1614201 12VDC  
P/N 1614301 24VDC

# SUPERWINCH®

Advantages  
**TALON**



These 2-stage planetary, 2-stage spur gear winches are packed with essential and extra practical features for efficient reliable and safe winching operations under the heaviest loads.

1. All seals on the entire winch from the outermost end of the high performance motor to the edge of the 2-stage planetary and 2-stage spur gearbox meet the IP67 standard.
2. Fastest line speed in its class; sealed 5.2 HP and 6.0 HP motors deliver a quick 25 FPM line speed at a low 75 Amp draw.
3. Four gear planetary sets, for added strength and durability. Robust ball and roller bearing construction.
4. Steel drum supports for ultimate strength; can be mounted foot down or foot forward, versatility provides multiple industrial mounting options.
5. Innovative "Dual-Stop" 100% load holding brake design provides zero drag on cable power in. Located inside the gearbox away from the drum to eliminate heat transfer to the synthetic rope.
6. Covered by a Limited Lifetime Warranty which includes an industry first 3-year warranty on all electrical components, the absolute BEST in the INDUSTRY!
7. Chrome plated aluminum ergonomic free spool knob lifts and turns effortlessly. Easily rotates in 45° increments for easy access for commercial and industrial applications.
8. Ergonomically shaped hand-held sealed remote with brilliant LED light assists in late night job site or road side winching.
9. Coiled cord extends to 15' and retracts to 4'. Includes strap to contain unit for storage. Connects to winch with military style twist lock plug, sealed to keep elements out.
10. VS4 Solenoid (Vented, Submersible, and Stabilized Solenoid with Sealed Socket) is the best winch solenoid in the world. Venting feature allows solenoid to resist water and releases contact damaging internal condensation. Tri-bar bracket includes steel-lined rubber insulated mounts to stabilize solenoid, reduces vibration and fatigue.







Advantages  
**TALON**

**SUPERWINCH**

**SUPERWINCH**

Technical Data, 14 & 18  
**TALON**



An easy to operate ergonomically designed chrome plated aluminum pull and turn freespool. Easily rotates in 45° increments for easy access with commercial and industrial applications.



Stainless Steel rollers with brushed finish endures weather and wire rope abuse.

Rollers are assembled with polybushings. The bolts use locknuts-not c-clips like on less expensive units which pop out if vehicle strikes a solid object. This can happen during off-road excursions or loading a vehicle onto a trailer - leaving the roller fairlead useless.



Welded construction for rugged applications - not just the bent metal used by many other winch suppliers and which is prone to failure.

Extreme-duty safety yellow latch switch Sling Hook with Half Link, 11,657.8 lbs (5299kg) Working Load with 4:1 safety factor. Recovery straps fit into larger 1.7" (43mm) opening with ease. Optional 1/2" Dyneema synthetic rope is terminated with heavy-duty gusseted tube thimble for ultimate strength and rope protection.



Ergonomically shaped hand-held sealed remote with brilliant LED light assists in late night job site or roadside winching.



1. Only Foot-Dow Mount winch available at these capacities.

2. Massive gears, Talon Large Chassis winches feature a monster gear set, over 45mm wide to promote positive engagement and long gear life.

3. Synthetic Rope Superwinch uses 1/2" certified Amsteel Blue Dyneema® rope for our large chassis Talon winches. Choosing synthetic rope can save as much as 25 lbs. over steel cable.

4. Limited Lifetime Warranty – Confidence on display – only Superwinch is bold enough to not only offer a Limited Lifetime Warranty, but also include an industry-leading 3 year electrical warranty.

No other manufacturer believes in their product like Superwinch.

Model	14	14SR	18	18SR
Part Number	1614200	1614201	1618200	1618201
Voltage	12 VDC	12 VDC	12 VDC	12 VDC
Rated Pull lbs (kg)	14,000 (6350)		18,000 (8165)	
Motor hp (kW)	5.2 (3.8)		6.0 (4.44)	
Gearing	2-Stage Spur/2-Stage Planetary			
Gear Ratio	346:1			
Solenoid	VS4 (Sealed Submersible Vented)			
Freespool	Ergonomic Pull and Turn			
Brake	Automatic, Load Holding, Located Outside Drum			
Rope Length ' (m)	90 (27.43)			
Rope Dia " (mm)	1/2 (13)			
Hook	Heavy Duty/Clevis Pinned/Latched, 14, 18 • Half Link Hook, 14SR, 18SR			
Fairlead/Hawse	Fairlead	Hawse	Fairlead	Hawse
Remote Control	Exclusive Ergo Handheld			
Installed lbs (kg)	170 (77.1)	145 (65.7)	172 (78)	147 (66)
Shipping lbs (kg)	183 (83)	158 (71.6)	185 (83.9)	160 (72.5)
Warranty	Limited Lifetime Plus 3-Year Electrical			
UPC	022705169127	022705169134	022705169141	022705169158
<b>Performance</b>	<b>14</b>	<b>14SR</b>	<b>18</b>	<b>18SR</b>
No Load Amps	75			
Line Speed FPM (MPM)	25 (7.62)			
At Load Amps	345		415	
Line Speed FPM (MPM)	4.25 (1.29)		2.5 (0.76)	
<b>Alternate Versions</b>	<b>14</b>	<b>14SR</b>	<b>18</b>	<b>18SR</b>
24VDC Versions:	1614300	1614301	1618300	1618301
No Rope 12VDC	1614202		1618202	
No Rope 24 VDC	1614302		1618302	

Mounting Bolt Pattern: 10" x 4.5" (254mm x 114.3mm) & 10" x 6.5" (254mm x 165.4mm)

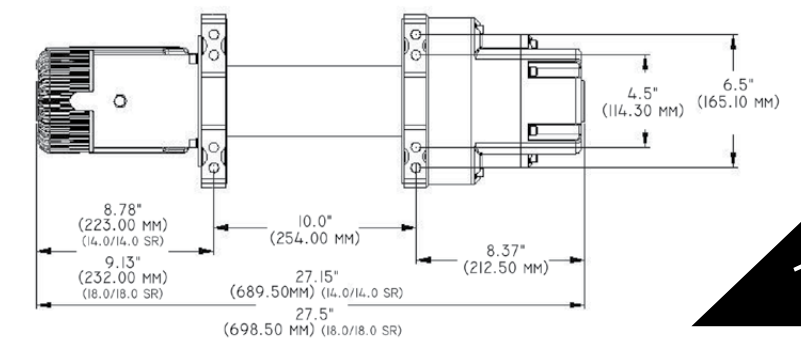
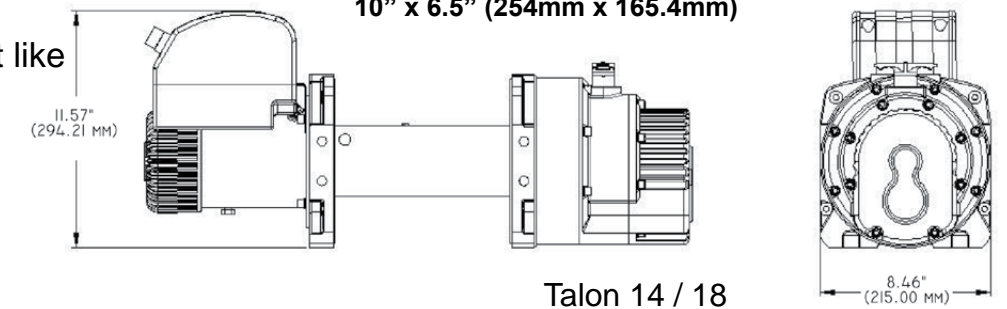



# TALON PRO 35 & 60

VEHICLE RECOVERY / COMMERCIAL / INDUSTRIAL / TRUCK and TRAILER



Superwinch PRO Series winches conform to EN 14492-1 Power Drive Winches and Machinery Directive 2006/42/EC



## TALON PROFESSIONAL SERIES

# SUPERWINCH®

## Advantages TALON PRO



### TALON 60 PRO 60K Electric Winch

P/N 61618001 12VDC (with rope)

P/N 61618003 12VDC (without rope)

P/N 61618002 24VDC (with rope)

P/N 61618004 24VDC (without rope)



Complies with, EN 14492-1 Specifications / 60kN (6020 kg) Single Line Pull

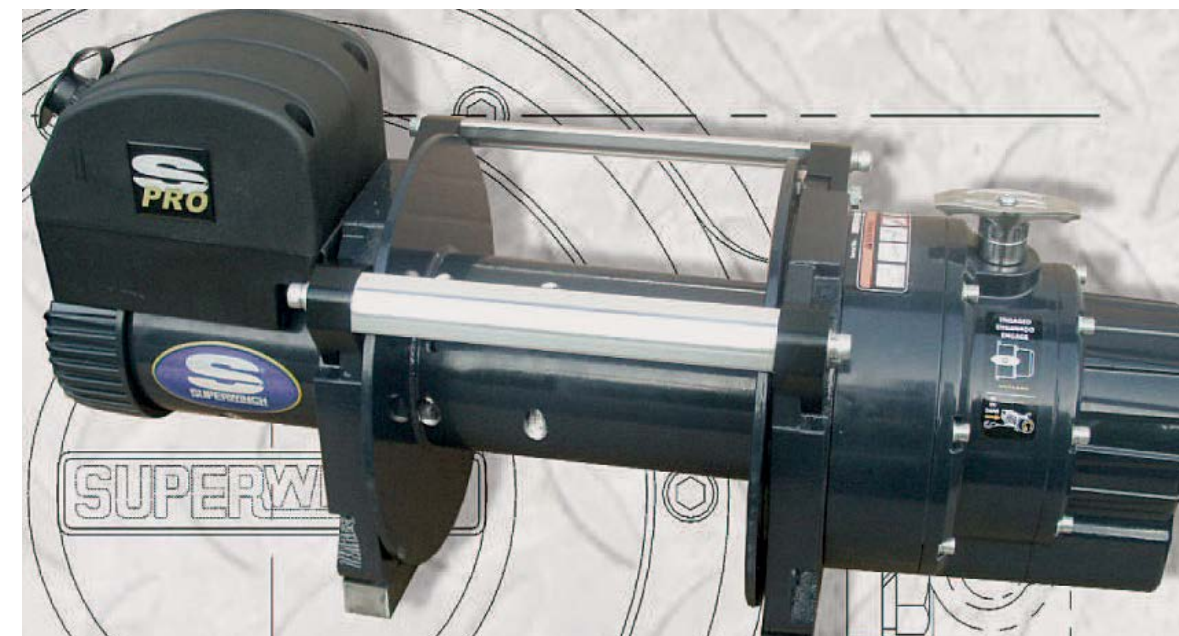

- Gear Reduction**.....Heavy duty planetary gearing, long reliable life, 346:1 ratio
- Drum**.....Heavy duty steel drum, mounted on low maintenance bearings
- Braking**.....Heavy duty automatic applied brake unit gives full load holding
- Load Limiting**.....Current sensing circuit breaker electronic cut-out (optional)
- Road Drum Cover**.....Rope drum safety guard (optional)
- Labelling**.....Rating plate displays: 1st layer and top layer, line pull figures

To ensure that winches are compliant with the European standard, EN 14492-1 Superwinch recommends that wire ropes should be as follows: 10mm diameter with a tensile grade of 1960 and a minimum break figure of: 7120 kg (69.8kN).



Advantages

**TALON PRO**

**SUPERWINCH**

# TALON 35 PRO 35K Electric Winch

- P/N 61614001 12VDC (with rope)
- P/N 61614003 12VDC (without rope)
- P/N 61614002 24VDC (with rope)
- P/N 61614004 24VDC (without rope)



Complies with, EN 14492-1 Specifications / 34.9kN (3558 kg) Single Line Pull



(Winch Shown with Optional Rope)

- Gear Reduction**.....Heavy duty planetary gearing, long reliable life, 346:1 ratio
- Drum**.....Heavy duty steel drum, mounted on low maintenance bearings
- Braking**.....Heavy duty automatic applied brake unit gives full load holding
- Load Limiting**.....Current sensing circuit breaker electronic cut-out (optional)
- Road Drum Cover**.....Rope drum safety guard (optional)
- Labelling**.....Rating plate displays, 1st layer and top layer, line pull figures

To ensure that winches are compliant with the European standard, EN 14492-1 Superwinch recommends that wire ropes should be as follows: 10mm diameter with a tensile grade of 1960 n/mm<sup>2</sup> and a minimum break figure of: 7120kg (69.8kN).

**SUPERWINCH**

Technical Data

**TALON PRO**



Twin Hole Safety Feature for Wire Rope Attachment.

Model	35 PRO	HS 35 PRO	HS 60 PRO
Part Number	61614001	61695001	61618001
Voltage	12 VDC	12 VDC	12 VDC
Rated Pull Kn (kg)	34.9 (3560)		59 (6018)
Motor hp (kW)	5.2 (3.8)		6.0 (4.44)
Gearing	2-Stage Spur/2-Stage Planetary		
Gear Ratio	346:1	148:1	346:1
Solenoid	VS4 (Sealed Submersible Vented)		
Freespool	Ergonomic Pull and Turn		
Brake	Automatic, Load Holding, Located Outside Drum		
Rope Length ' (m)	98 (30)		
Rope Dia " (mm)	3/8 (10)		1/2 (13)
Hook	Permanant		
Fairlead/Hawse	Fairlead		
Remote Control	15' Sealed Ergonomic Hand-Held with Coiled Cord		
Installed lbs (kg)	170 (77.1)		172 (78)
Shipping lbs (kg)	183 (83)		185 (83.9)
Warranty	Limited One Year		

Performance		35 PRO	HS 35 PRO	60 PRO
No Load	Amps	75	75	75
	Line Speed			
	FPM (MPM)	25 (7.62)	79.7 (24.3)	28.8 (8.8)
At Load	Amps	350	520	430
	Line Speed			
	FPM (MPM)	4.25 (1.29)	4.25 (1.29)	2.5 (0.76)

Alternate Versions

	35 PRO	HS 35 PRO	60 PRO
24VDC Versions:	61614002	61695002	61618002
No Rope 12VDC	61614003	61695003	61618003
No Rope 24 VDC	61614004	61695004	61618004

Mounting Bolt Pattern: 10" x 4.5" (254mm x 114.3mm) small frame  
10" x 6.5" (254mm x 165.4mm) large frame



TALON 35 PRO

(TALON 60 PRO)

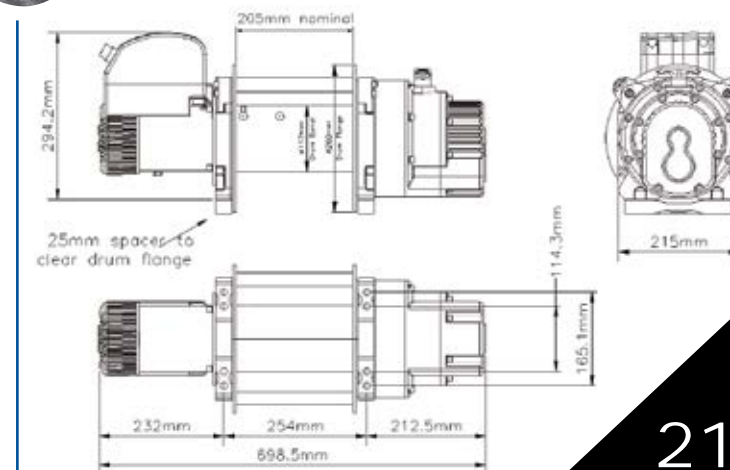
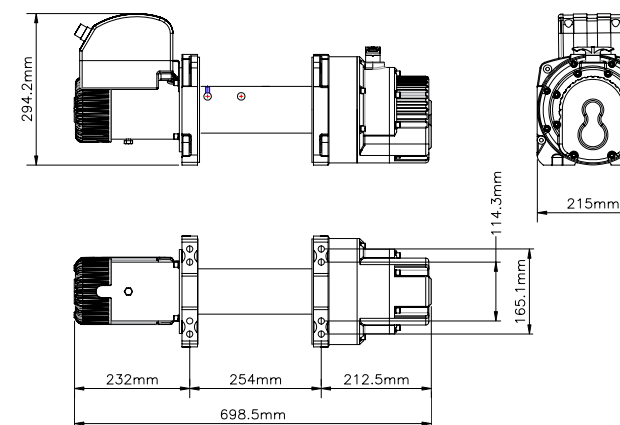



# TALON Mil Spec Series

DEFENCE / SECURITY / LAW ENFORCEMENT



When every minute counts and only the best will get the job done - you want the Talon Mil Spec Series on your side.



**Talon Mil Spec 70kN**  
P/N 61618100 12VDC  
P/N 61618101 24VDC

**Talon Mil Spec 35kN**  
P/N 61695100 12VDC  
P/N 61695101 24VDC

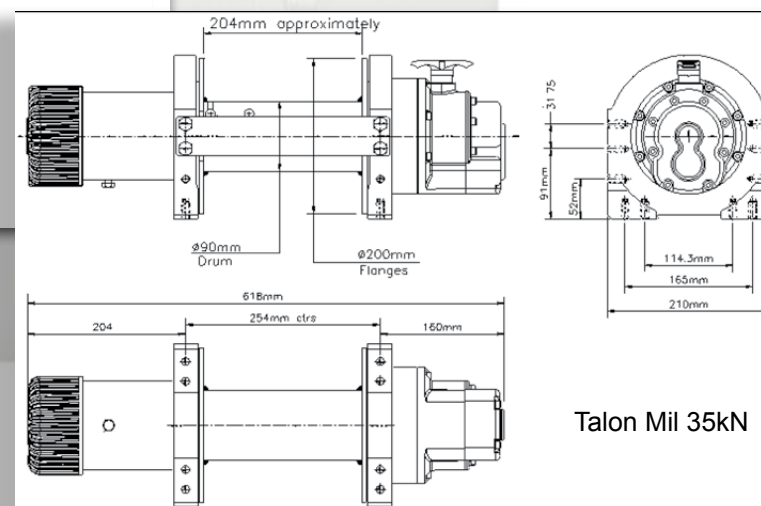
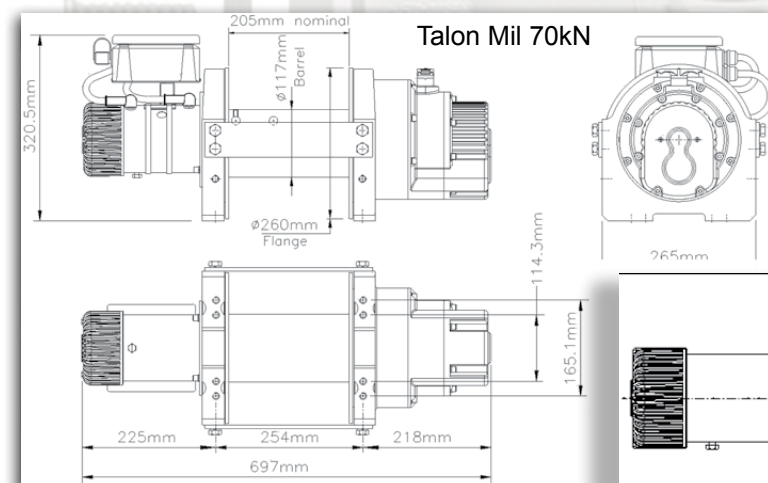

Talon Mil 35kN



# Technical Data TALON Mil SPEC



Model	Talon M-35		Talon M-41		Talon M-80	
Part Number	61695100	61695101	61612100	61612101	61618100	61618101
Voltage	12 VDC	24 VDC	12 VDC	24 VDC	12 VDC	24 VDC
Rated Pull lbs (kg)	7,848 (3560)		9,038 (4100)		15,741 (7140)	
Motor hp (kW)	5.2 (3.8)				6.0 (4.44)	
Gearing	2-Stage Spur/2-Stage Planetary					
Gear Ratio	148:1				346:1	
Solenoid	VS4 (Sealed, Submersible, Vented)					
Freespool	Ergonomic Pull and Turn					
Brake	Heavy Duty, Automatic, Load Holding, Located Outside of Drum					
Rope Length ' (m)	N/A (Recommended 30m)					
Rope Dia " (mm)	N/A (Recommended: 10m, 19/60 grade,				13mm, 19/60 grade)	
Hook	N/A					
Fairlead/Hawse	Roller Fairlead					
Remote Control	15' Rubber Remote					
Installed lbs (kg)	74.9 (34)				132 (60)	
Shipping lbs (kg)	89.9 (40.36)				147 (66.6)	
Warranty	Limited 1 Year Warranty					
Load Limiting	Electronic Cut Off (Solid State)					

Performance	Talon M-35		Talon M-41		Talon M-80	
No Load Amps	75		75		75	
Line Speed FPM (MPM)	82 (25)		82 (25)		29.5 (9.0)	
At Load Amps	520	375	540	390	475	355

Options		Mounting Bolt Pattern: 10" x 4.5" (254mm x 114.3mm) small frame 10" x 6.5" (254mm x 165.4mm) large frame 10" x 8.2" (254mm x 210mm) extra large frame
Roller Fairlead	90-32473	
Cable Tensioner	16-90734	
10mmx30m Wire Cable	0563S	
Flat Bed Mount Plate	258001	

- Gear Reduction**.....Heavy duty planetary spur gearing, for long reliable life
- Support Housing**.....Heavy duty cast aluminium for long reliable service
- Drum**.....Heavy duty steel drum, mounted on low maintenance bearings
- Braking**.....Heavy duty automatic brake gives full load holding
- Load Limiting**.....Electronic cut-out (solid-state)
- Construction**.....Built to IP67 specifications, fully submersible to 1 meter.

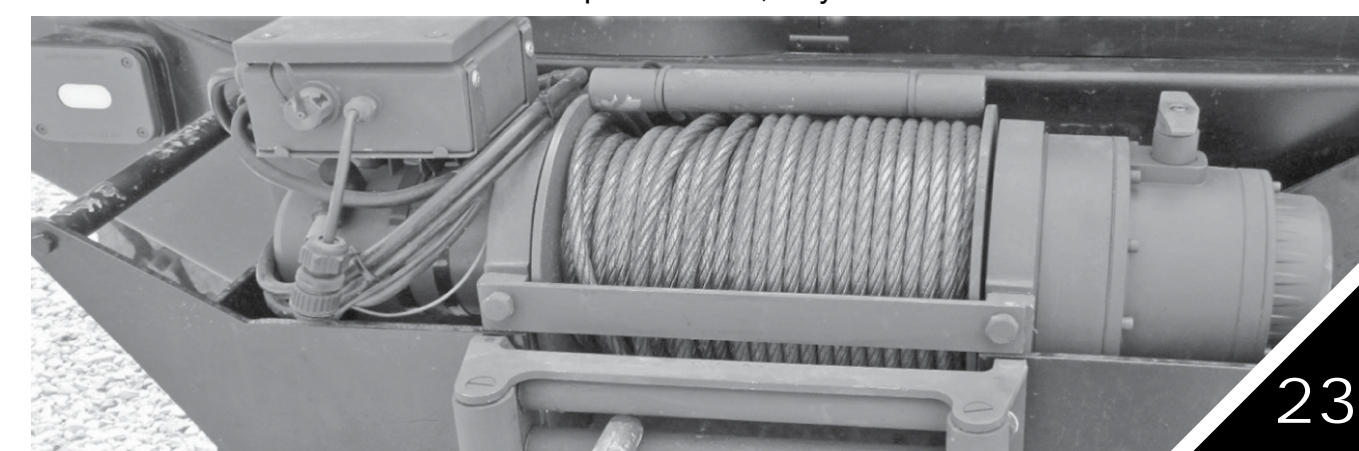



# E12P / E14P

Vehicle Recovery / Industrial / Truck



**Electrical Powered Heavy Duty Planetary Winches - designed and manufactured to provide years of trouble free operation.**

- Gear Reduction**.....Heavy duty planetary gearing, long reliable life, 370:1 ratio
- Drum**.....Heavy duty steel drum, mounted on copolymer maintenance free bearings
- Braking**.....Heavy duty bi-directional, full load holding, electrically released spring applied
- Mounting**.....Winch can be foot or low mounted at any angular orientation
- Control Solenoid**.....Enclosed assembly remotely mounted
- Freespool**.....Operated by an ergonomically designed handle and trigger mechanism, that locks in both engaged and disengaged positions

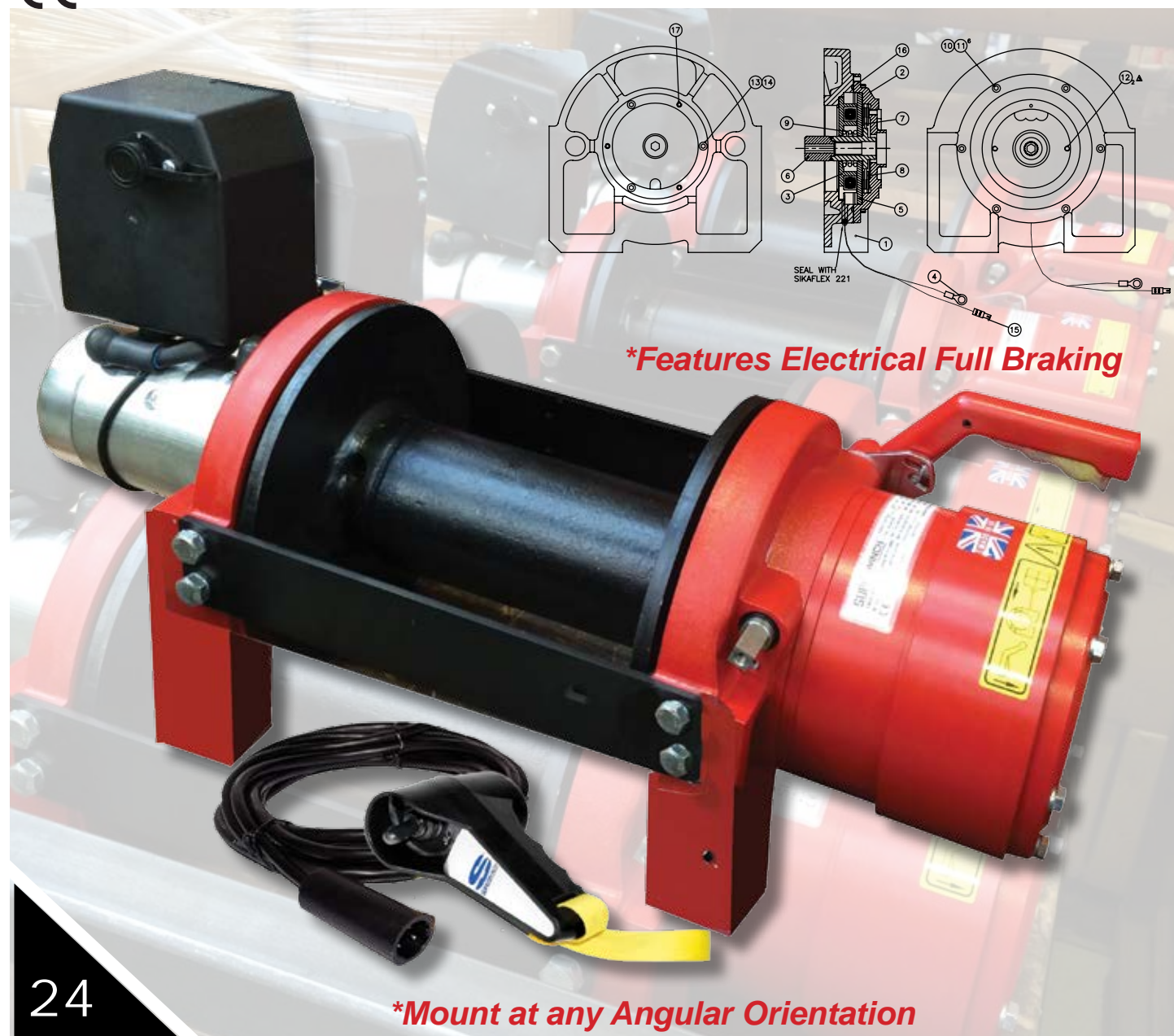

# SUPERWINCH®

Technical Data  
**Electrical P SERIES**



Model	E12P	E12P	E12P	E12P	E14P	E14P
Part Number	5229	5230	5231, 5231SK 5231KNT	5232	5233, 5233SK	5234, 5234SK
EN14492 Complaint	No					
Electric Motor	12V DC			24V DC		
Rated Pull Bottom layer lbs (kg)	11,982.3 (5435.1)				14,005.5 (6353.0)	
Current Draw, at rated line pull	420 A	400 A	195 A	235 A		
Gearing	Planetary					
Gear Ratio	370:1					
Solenoid	Enclosed solenoid, remotely mounted					
Remote Switch, feet/meters	11.48 (3.5)					
Freespool	Ergonomic, locking Engaged and Unengaged, Manual Release Lever					
Brake	Integral, bi-directional, Full Load Holding, Electrically Released					
Mounting	Winch can be foot or low mounted at any angular orientation.					
Recommended Rope Length ' (m)	164.04 (50)	246.06 (55)	164.04 (50)	245.06 (55)	118.11 (36)	1137.79 (42)
Recommended Rope Dia " (mm)	0.478 (12)				1/2 (13)	
Weight Installed, no rope, lbs (kg)	134.48 (61)					
Warranty	Limited One Year Warranty					
<b>Performance</b>						
No Load 1st Layer Line Speed FPM (MPM)	32.80 (10)				19.0 (5.8)	
<b>Alternate Version</b>						
Long Drum Model		√		√		√
<b>Accessories</b>						
Roller Fairlead, part number	-	5620	5610	5620	5610	5620
Cable Tensioner, part number	-	5670	5637	5670	5637	5670
Mount Plate	All					

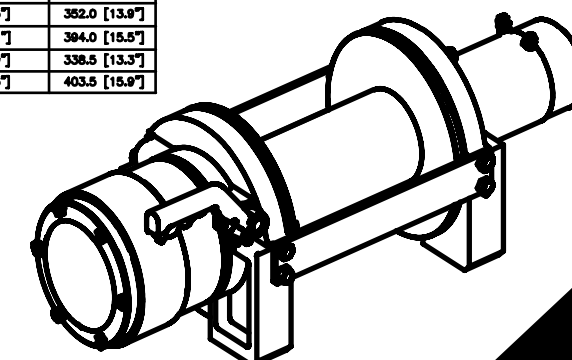
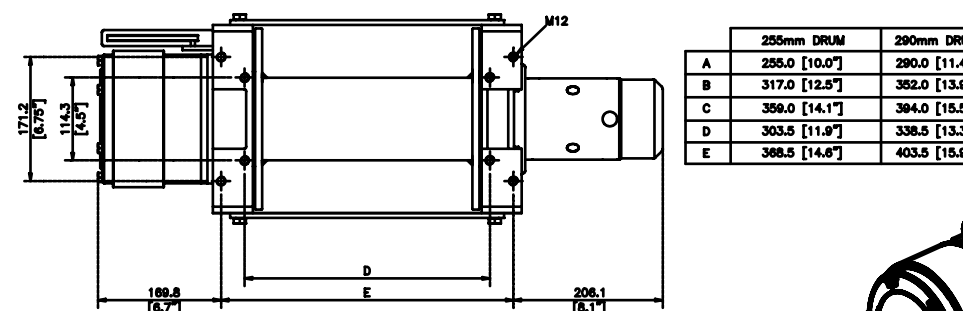
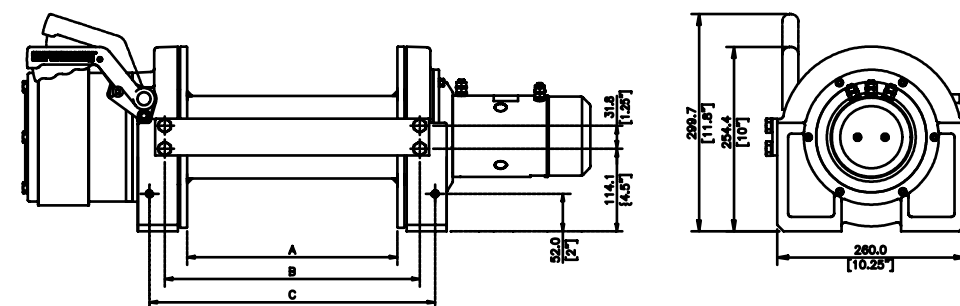

# SUPERWINCH®

Some Superwinch products are not sold globally, please call 1.800.323.2031, in the U.S.A. or +44 (0) 1822 614101, in the UK for availability.

**High Performance Series - Extreme Duty Worm Gear Winches**  
Designed and engineered in England, the Husky Series from Superwinch® contains a virtually indestructible worm and spur gear system.

- Built to Bill Burke's specifications
- 3/8" x 80' Dyneema
  - Heavy Duty Roller Fairlead
  - Latched Sling-Hook with 1/2 link.

*Bill Burke, "I was introduced to the Superwinch Husky over 25 Years ago with my involvement with the Camel Trophy. I recognized a quality, industrial grade product that could reliably withstand constant use and abuse."*



**Bill Burke HUSKY 10**  
P/N 2404BB



**Synthetic rope friendly (worm gear drive will not degrade the synthetic rope).**  
**Back-drive resistance, load-holding brake system. Remote mountable solenoid housing.**



**HUSKY 8.5**  
P/N 2401A



**Mounting Bolt Pattern: 10.8" x 4.92" (275mm x 125mm)**

- |       |   |
|-------|---|
| 2401  | Husky 8.5, 12V with 3/8" x 90' rope (North America)                         |
| 2401A | Husky 8.5, 12V with 3/8" x 90' rope & roller fairlead (North America)       |
| 8514  | Husky 8.5, 12V (winch only)   |
| 8515  | Husky 8.5, 24V (winch only)   |
| 8532  | Husky 8.5, 12V with roller fairlead & mount plate                           |
| 8533  | Husky 8.5, 24V with roller fairlead & mount plate                           |
| 8552  | Husky 8.5, 12V with roller fairlead and 9mm x 31M rope (no electric cables) |
| 8553  | Husky 8.5, 24V with roller fairlead and 9mm x 31M rope (no electric cables) |

- |       |  |
|-------|--|
| 2404  | Husky 10, 12V with 3/8" x 90' rope (North America)                   |
| 2404A | Husky 10, 12V with 3/8" x 90' rope & roller fairlead (North America) |
| 2405  | Husky 10, 24V with 3/8" x 90' rope & roller fairlead (North America) |
| 8548  | Husky 10, 12V with 10mm x 30M rope & roller fairlead                 |
| 8549  | Husky 10, 24V with 10mm x 30M rope & roller fairlead                 |

- |        |  |
|--------|--|
| 2422   | Husky 12, 12V with 3/8" x 90' rope & roller fairlead (North America) |
| 685011 | Husky 12, 12V (winch only)   |
| 685012 | Husky 12, 24V (winch only)   |
| 685013 | Husky 12, 12V with 10mm x 21M rope & roller fairlead                 |
| 685014 | Husky 12, 24V with 10mm x 21M rope & roller fairlead                 |
| 685015 | Husky 12, 12V with 10mm x 21M rope & roller fairlead, mount plate    |
| 685016 | Husky 12, 24V with 10mm x 21M rope & roller fairlead, mount plate    |

SAE J706



1. Tested around the world - the iconic Superwinch Husky has crisscrossed the globe in trophy competition. Time and time again, the pros turn to the Superwinch Husky for reliability, dependability and long service life.

2. VS3 Solenoid - (VS3, USA only)  
The Superwinch Husky features the VS3 solenoid, sealed and submersible, and carries the industry leading 3-year electrical warranty.



3. Worm Drive - The key to the Husky's drive is the worm and spur gear system. Carefully machined, the worm gear provides simple, reliable torque and world-class braking. No other system comes close.

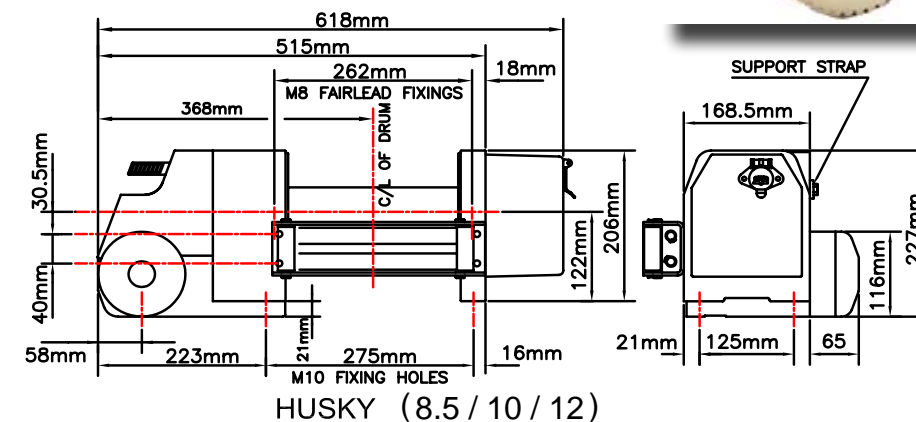
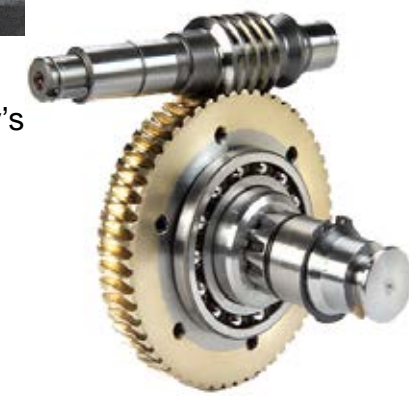



# HUSKY PRO SERIES

Vehicle Recovery / Truck / Utility



## HUSKY PRO Electric Winch



Complies with, EN 14492-1 Power Driven Winches and Machinery Directive 2006/42/EC

HUSKY PRO 12V  
P/N 8532 PRO

Shown with optional  
rope drum safety guard



**8514PRO** Husky-PRO, 12VDC, Winch Only

**8515PRO** Husky-PRO, 24VDC, Winch Only

**8532PRO** Husky-PRO, 12VDC, Roller Fairlead & Mount Plate

**8533PRO** Husky-PRO, 24VDC, Roller Fairlead & Mount Plate

**Features**.....EU spec line pull, 24.5kN (2500 kg) Design line pull 37.8kN (3860 kg)  
10:1 D:d ratio rope drum

**Wire Rope**.....2:1 safety factor

**Wire Rope Fixture**.....Twin hole safety feature

**Gearing**.....Heavy duty worm and worm wheel set

**Load Limiting**.....Factory set thermal overload cut out

**Labelling**.....Rating plate displays: 1st layer and top layer, line pull figures

**Brake**.....Irreversible worm and worm wheel action, full load-holding brake

Mounting Bolt Pattern: 10.8" x 4.92" (275mm x 125mm)

## HUSKY PROFESSIONAL SERIES

Some Superwinch products are not sold globally, please call 1.800.323.2031,  
in the U.S.A. or +44 (0) 1822 614101, in the UK for availability.



Technical Data  
**HUSKY**



Model	8.5	10	10BB	PRO	12
Part Number	8514A	2404A	2404BB	8514PRO	2422
Voltage	12 VDC	12 VDC	12 VDC	12 VDC	12 VDC
Rated Pull lbs (kg)	8,500 (3856)	10,000 (4536)		5,511 (2500)	12,000 (5443)
Motor hp (kW)		4.2 (3.13)		1.9 (1.43)	6.0 (4.48)
Gearing	Worm Gear				
Gear Ratio	229:1		294:1		
Solenoid	North America: VS3 / EU/UK: Metal Solenoid				
Freespool	Lever Control				
Brake	Automatic, 100% Load Holding				
Rope Length ' (m)	Optional	90 (27)	80 (24.4)	Optional	98.4 (30)
Rope Dia " (mm)	13/64 (9.0)	3/8 (9.5)	3/8 (9.5)	5/16 (8.0)	19/60 (10)
Hook	North America: Clevis Pinned / EU/UK: Permanent				
Fairlead/Hawse	Heavy Duty Roller Fairlead				
Remote Control	15' Sealed Handheld				
Installed lbs (kg)	112.9 (51)	88 (39.9)	88 (39.9)	112.9 (51)	123.9 (56.2)
Shipping lbs (kg)	123.9 (56.2)	95 (43.09)	95 (43.09)	123.9 (56.2)	123.9 (56.2)
Warranty	Limited Lifetime				
UPC	02270502408	022705024044	022705023032		
Performance	8.5	10	10BB	PRO	12
No Load Amps	62	62	62	55	62
Line Speed FPM (MPM)	22.6 (6.9)				
At Load Amps	450			240	360
Line Speed FPM (MPM)	1.5 (0.5)				
Alternate Versions	8.5	10	10BB	PRO	12
24VDC Versions:	8515	2405		8515 PRO	685012
No Rope 12VDC					685011
No Rope 24 VDC					685013

Mounting Bolt Pattern: 10.8" x 4.92" (275mm x 125mm)

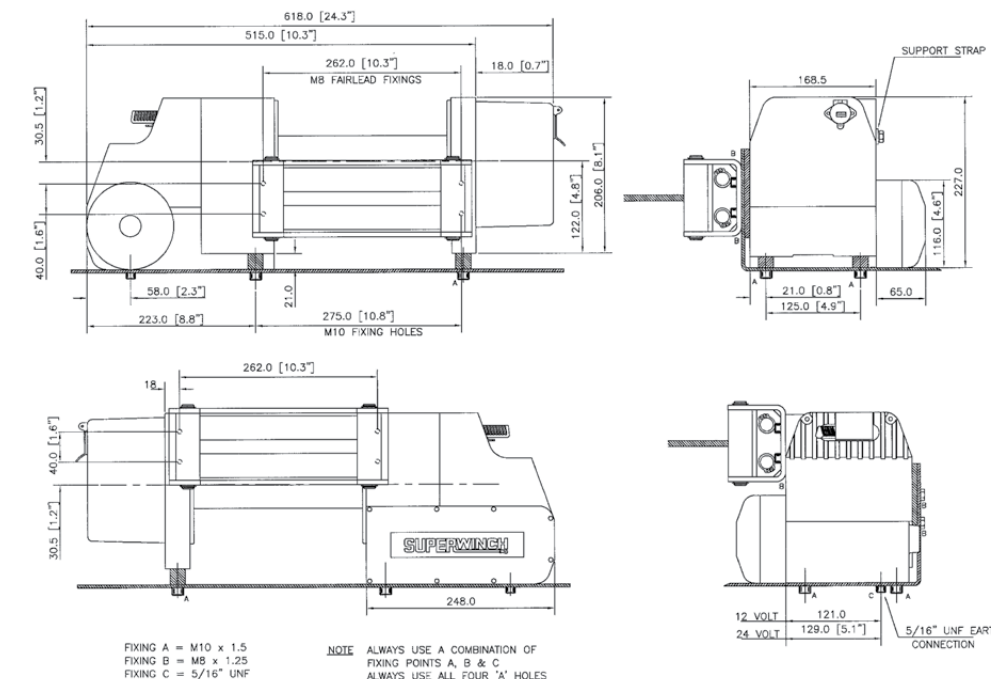



# X/S SERIES

VEHICLE RECOVERY / OFF ROAD / TRUCK / SUV



With its rugged and long lasting differential planetary gearbox, the Superwinch X9 and S9000 Series ensure years of dependable service. If you want a winch to perform in your "Outback", the X/S Series is the winch for your vehicle!



**X9**  
P/N 1901C 12VDC  
P/N 1902B 24VDC



The Superwinch X-9 is so tough; The Original Equipment winch for the Toyota HiLux, LandCruiser 70, LandCruiser 200 and the Prado in Australia. The Toyota Genuine Superwinch is the ultimate accessory for the serious off road enthusiast. The X9 is available in 12VDC and 24V DC, Built in the USA.

Equipped with a powerful electric motor and a compact heavy duty solenoid unit, the Superwinch X9 delivers up to 9,000 lbs (4082 kg) pulling capacity to help you out of tricky off road situations while its durable, rubberized hand remote control with water proof toggle switch is designed for safe and dependable operation. The "dual" metal solenoid system can be mounted directly on the winch or can be remotely mounted for remote access.

**S9000**  
P/N 1917 12VDC  
P/N 1918 24VDC



The Superwinch S9000 Heavy Duty winch has a 15-year legacy; Built to Last! With a rugged long lasting differential planetary gearbox, these winches ensure years of dependable service. The sealed and submersible S3 solenoid system is mounted directly over the winch drum within an all aluminum bridge for a sleek performance appearance. We have implemented an exclusive 3-year warranty on our robust S3™ Solenoid. The S9000 is available in 12VDC and 24VDC, Built in the USA.



# Technical Data

## X/S SERIES



Model	X9	S9000
Part Number	1901C	1917
Voltage	12VDC	
Rated Pull lbs (kg)	9,000	
Motor hp (kW)	4.2 (3.13)	
Gearing	Planetary Differential	
Gear Ratio	253:1	
Solenoid	VS3	
Freespool	1/4 Turn Clutch	
Brake	Automatic/100% Load Holding	
Rope Length ' (m)	100 (30.5)	
Rope Dia " (mm)	5/16 (7.9)	
Hook	Heavy Duty/Clevis Pinned/Latched	
Fairlead/Hawse	Heavy Duty 4-way Roller	
Remote Control	15' Heavy Duty Rubber Remote	
Weight Installed lbs (kg)	82 (37)	84 (38)
Weight Shipping lbs (kg)	95 (43)	96 (43.5)
Warranty	Limited Lifetime/3-Year Electrical	
UPC	033705190220	02270519170



**Heavy Duty-**  
Differential Planetary Gearbox

Performance		
No Load	Amps	43
	Line Speed fpm (mpm)	38.2 (11.6)
At Load	Amps	420
	Line Speed fpm (mpm)	2.5 (0.8)

Mounting Bolt Pattern: 10.8" x 4.92"  
(275mm x 114,3mm)

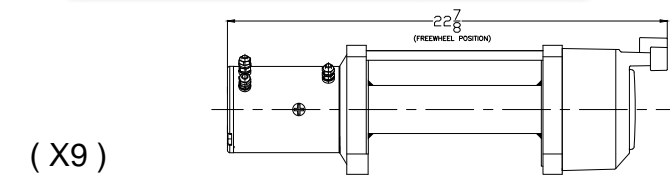
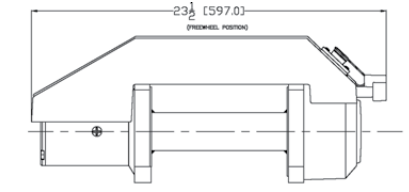

(X9)

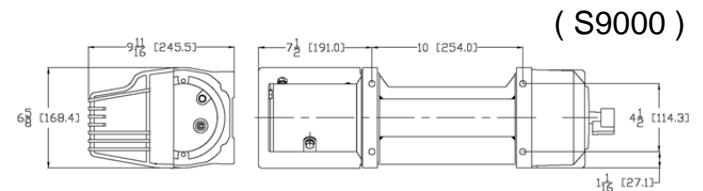

(S9000)

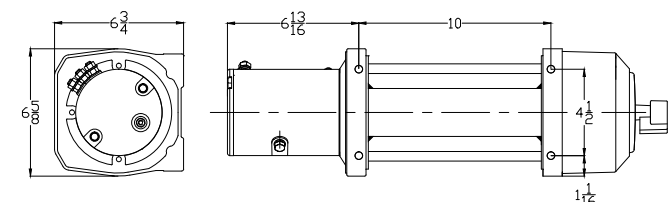





# TIGER SHARK 9.5 / 11.5

VEHICLE RECOVERY / OFF ROAD / UTILITY



Superwinch is redefining the entry level winch market with the new Tiger Shark Series with "Standard Issue" features and benefits designed specifically for the enthusiast-level consumer. Created from everything we learned over the past 40+ years, the Tiger Shark brings unmatched functionality, quality and value. The automatic load holding brake design is located on the end of the motor away from the drum's center to eliminate heat transfer to the synthetic rope. A special steel drum is constructed with high tensile strength material to resist the unique loading characteristic of the optional synthetic 3/8" x 80' rope rated at over 17,000 lbs ensures a safe pull.



TS 11500 P/N 1511200 12VDC  
P/N 1511201 12VDC with Synthetic rope (shown)  
P/N 1511300 24VDC



Utility & Multi



TS 9500 P/N 1595200 12VDC (shown)  
P/N 1595201 12VDC with Synthetic rope  
P/N 1595300 24VDC

# SUPERWINCH®

## Advantages TIGER SHARK



1. From 9,500 to 17,500 - This 5 winch program is one of the most robust. From the fully-tested-to-stall drum supports to severe-duty textured finish, Tiger Shark is a winch series that's earned its stripes.
2. Go ahead, dare to compare – Tiger Shark eats the competition for lunch. 3 and 4 stage gearboxes powered by 5.2 and 6.5 horsepower motors keep the Tiger Shark above all comers. Superwinch's legacy inspires this ultra popular winch series.
3. Stainless steel parts - The Tiger Shark series from Superwinch feature upgrades most winches at this level lack. By choosing stainless steel hardware, tie bars and fairlead rollers, Superwinch is insuring your winch will not only avoid rusting but will look great in the long run.
4. Pull and Turn Freespool, shaped for ergonomics, the pull and turn freespool knob on the Superwinch Tiger Shark is insurance against accidental freespooling.
5. Weather Sealed, 5.2 HP to 6.5 HP motors reduces damage from rain, snow and blowing dust.

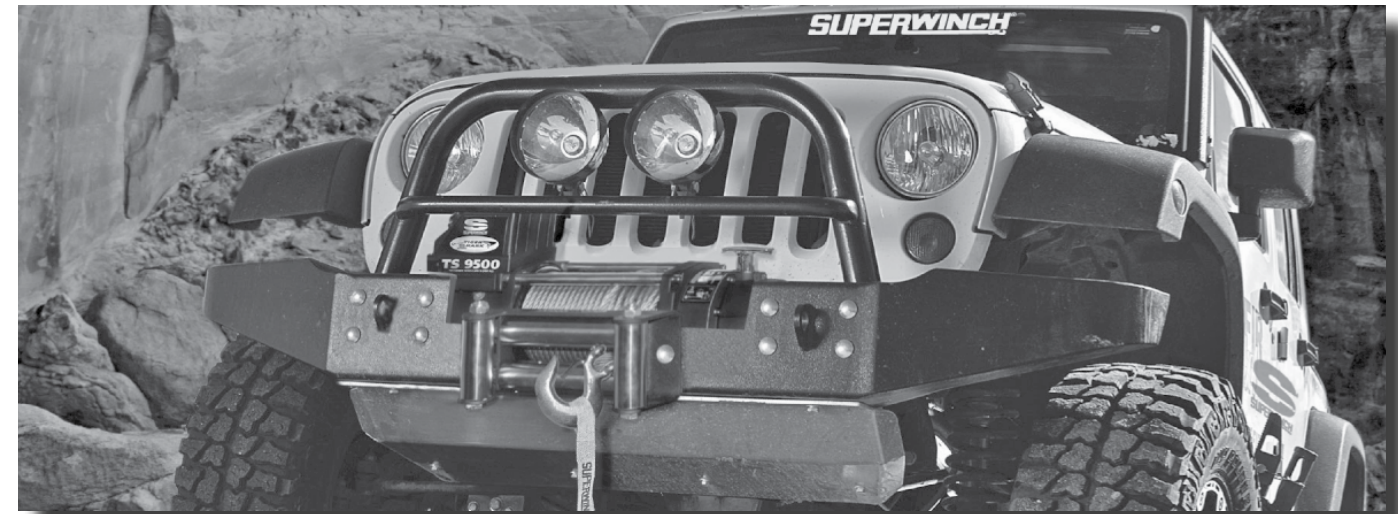



**TIGER SHARK 13.5 / 15.5 / 17.5**  
VEHICLE RECOVERY / OFF ROAD / UTILITY



**TS 1750**  
P/N1517200

**TS 1550**  
P/N 1515200 12VDC 15,500 lb (7031 kg)



**SUPERWINCH**

Technical Data  
**TIGER SHARK**



Model	9500	11500	13500	15500	17500	
Part Number	1595200	1511200	1513200	1515200	1517200	
Voltage	12 VDC	12 VDC	12 VDC	12 VDC	12 VDC	
Rated Pull lbs (kg)	9,500 (4309)	11,500 (5216)	13,500 (6123.5)	15,500 (7031)	17,500 (7938)	
Motor hp (kW)	5.2 (3.8)	6.0 (4.44)	5.3 (3.95)	5.7 (4.25)	6.5 (4.84)	
Gearing	3-Stage Planetary		4-Stage Planetary			
Gear Ratio	218:1		518:1			
Solenoid	Weather Sealed					
Freespool	Ergonomic Pull and Turn					
Brake	Mechanical, Automatic, Load Holding					
Rope Length ' (m)	95 (29)	84 (26)	95 (29)	92 (28)	90 (27.4)	
Rope Dia " (mm)	21/64 (8.3)	3/8 (9.5)	13/32 (10.3)	29/64 (11.5)	1/2 (12.7)	
Hook	Heavy Duty/Clevis Pinned/Latched					
Fairlead/Hawse	Stainless Steel 4-way Roller Fairlead					
Remote Control	Rugged Rubberized Handheld					
Weight Installed lbs (kg)	90 (41)	94 (42)	134 (60.7)	140 (63.5)	150 (68)	
Weight Shipping lbs (kg)	94 (42)	98 (44)	138 (62.5)	144 (65)	154 (70)	
Warranty	Limited 2-Year Warranty / 1-Year Electrical					
UPC	022705003605	022705003612	022705003629	022705003636	022705003643	
Performance	9500	11500	13500	15500	17500	
No Load	Amps	80		120		
	Line Speed	19 (5.7)		11 (3.4)		
	FPM (MPM)	19 (5.7)		11 (3.4)		
At Load	Amps	340		440		
	Line Speed	4 (1.2)	2 (0.6)	4 (1.2)	3.5 (1)	2.8 (0.85)
	FPM (MPM)	4 (1.2)	2 (0.6)	4 (1.2)	3.5 (1)	2.8 (0.85)

Mounting Bolt Pattern: 10" x 4.5" (all models)

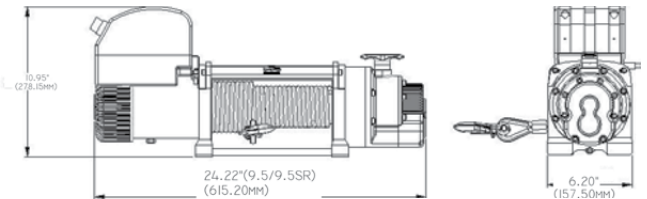

( TS 9500 / 11500 )

( TS 13500 / 15500 / 15500 / 17500 )

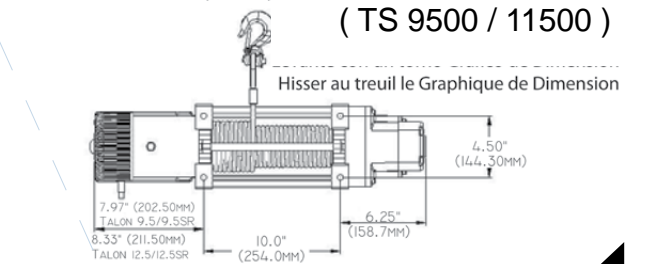
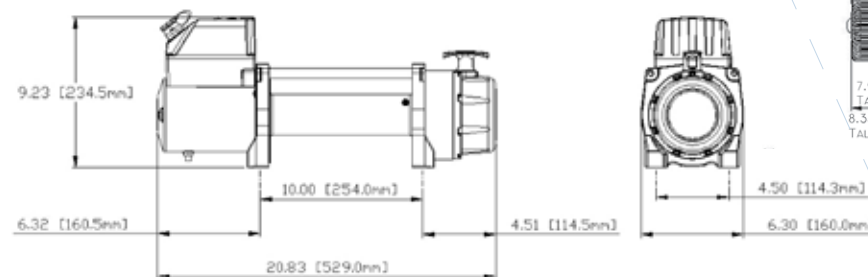

Hisser au treuil le Graphique de Dimension



# LP 8500 / LP 10000

VEHICLE RECOVERY / OFF ROAD / UTILITY



Superwinch's LP8500 and LP10000 winches are designed to accommodate entry-level buyers shopping for excellent value. Meeting the rugged demands of off-road and utility use, the LP8500 and LP10000 introduces price-conscious buyers to the quality, power, and performance advantages of the Superwinch brand.



**LP 8500**  
P/N 1585202

Superwinch's LP8500 8500 lbs (3856 kg) winch is designed as a great winch for those looking for an 8000 lbs winch class performer.



**LP 10000**  
P/N 1510200

The LP 10000 provides reliable, powerful 10,000 lbs (4536 kg) of performance for intermediate level off-road and utility applications. This is the big brother to the very popular LP8500; we added a stronger 5.1 HP weather sealed motor, bigger 3/8" wire rope and replaced the steel hawse with a heavy duty 4-way roller fairlead.

# SUPERWINCH®

## Technical Data LP 8500 / LP 10000



Model	8500	10000	
Part Number	1585202	1510200	
Voltage	12 VDC	12 VDC	
Rated Pull lbs (kg)	8,500 (3856)	10,000 (4536)	
Motor hp (kW)	4.5 (3.33)	5.1 (3.8)	
Gearing	3-Stage Planetary		
Gear Ratio	235:1		
Solenoid	Sealed Solenoid With Circuit Breaker		
Freespool	Lever Shift		
Brake	Automatic/Load Holding		
Rope Length ' (m)	95 (29)	85 (25.9)	
Rope Dia " (mm)	5/16 (7.9)	3/8 (9.5)	
Hook	Heavy Duty/Clevis Pinned/Latched		
Fairlead/Hawse	Steel Hawse	Roller Fairlead	
Remote Control	12' Rubber Handheld		
Weight Installed lbs (kg)	73 (33.11)	83 (37.64)	
Weight Shipping lbs (kg)	90 (40.83)		
Warranty	Limited 2-Year Warranty		
UPC	0227050003407	00227050003414	
Performance	8500	10000	
No Load	Amps	84	90
	Line Speed FPM (MPM)	18 (5.5)	16 (4.87)
At Load	Amps	320	350
	Line Speed FPM (MPM)	3.5 (1.1)	1.52 (.46)

Mounting Bolt Pattern: 10.8" x 4.5" (254mm x 114.3mm)

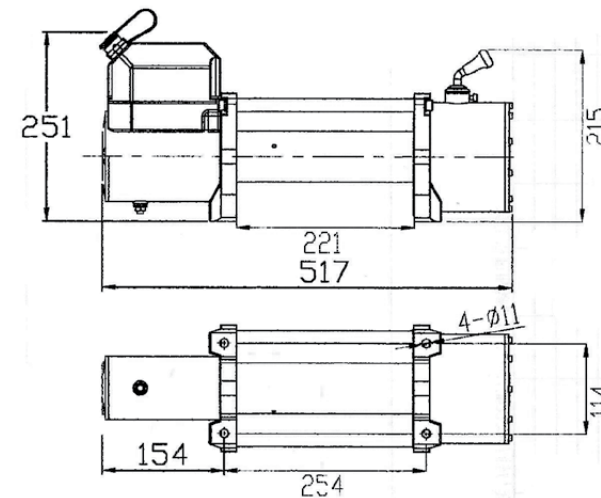

( LP8500 / LP10000 )

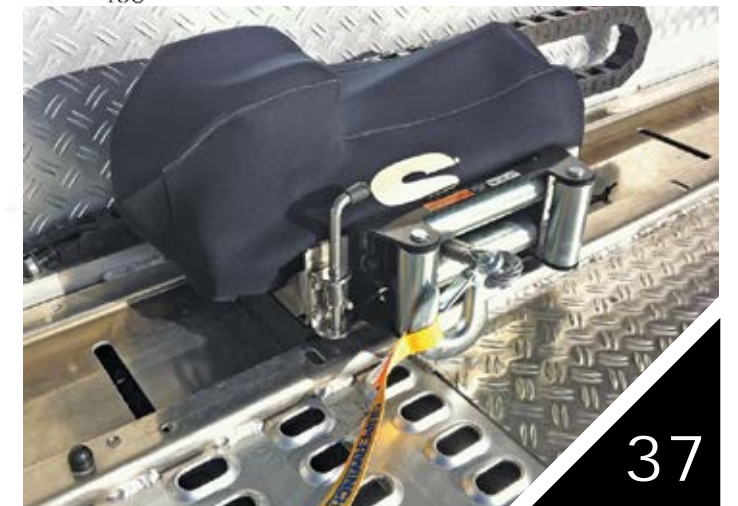
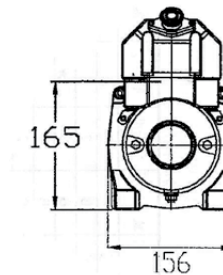



# S 3000 / S 4000 / S 5000

VEHICLE RECOVERY / TRAILER / UTILITY



Full metal gears deliver the power and performance preferred by the professionals for safe, dependable loading. Hand-held switch on 30' of rubber cord is included. Instant stop design ensures absolutely no coasting. Lever operated clutch simplifies fast wire rope payout. S3 Solenoid is submersible, sealed and comes with an exclusive 3-year warranty. The S4000 and S5000 feature power IN and power OUT, free-spooling drum, mechanical and dynamic braking, and a roller fairlead. The fully enclosed housing helps keep the weather out. No wonder they call these winches "The Racer's Choice!"

## SUPERWINCH



### S 3000

P/N1430200 12VDC  
P/N1430300 24VDC



### S 4000

P/N1440200 12VDC  
P/N1440300 24VDC



### S 5000

P/N1450200 12VDC  
P/N1450300 24VDC



OPTIONAL



# SUPERWINCH®

## Advantages S SERIES



1. Superwinch knows Trailers. As the #1 brand of trailer winches, Superwinch is the leader in trailer-specific winching. Reliability is just the beginning.
2. Remote. From the 30 (9m) foot cord remote to the new optional CERTUS™ Wireless Remote, Superwinch has the options trailer owners want. The CERTUS™ operates on a reliable FM frequency and is the most reliable wireless remote ever tested by Superwinch Labs.
3. Weather protected. From the VS<sup>3</sup> submersible sealed solenoid, submersible sealed hand held remote to the weather resistant cover and drum window, the S Series of winches is at home indoors or out.
4. Brakes. Winching onto a trailer is no time to find out your winch isn't ready for travelling. Off-road winch brakes won't offer the sure grip that the S Series provides each and every pull. With zero-coasting, the Superwinch S Series is a real, honest-to-goodness trailer winch.





# S 4000 SR / DANNY O'DAY

/ TRAILER / VEHICLE RECOVERY / UTILITY



"Whichever trailer you're loading there's a Superwinch designed to deliver the power to meet your needs. I've been using Superwinch products for over 20 years. My job is wheel standing and entertaining crowds of race enthusiasts from all over the world. ---Danny O'Day



Danny O'Day  
P/N 1450200DD 12VDC



S 4000SR  
P/N 1440200SR 12VDC



# SUPERWINCH®

## Technical Data S SERIES



Danny O'Day

Model	S3000	S4000	S4000SR	S4000DD	S5000
Part Number	1430200	1440200	1440200SR	1450200DD	1450200
Voltage	12VDC				
Rated Pull lbs (kg)	3,000 (1361)	4,000 (1814)	Rolling wt. 6,400 (2903)		5,000 (2268)
Motor hp (kW)	1.3 (0.96)	1.8 (1.34)		2.1 (1.57)	
Gearing	Planetary Differential				
Gear Ratio	159:1				
Solenoid	Duel Can Style	VS3, sealed submersible			
Freespool	Lever Action				
Brake	Automatic/50% First Wrap Spring				
Rope Length ' (m)	60 (18.2)	50 (15.2)		40 (12.2)	
Rope Dia " (mm)	3/16 (4.8)	7/32 (5.6)		1/4 (6.4)	
Hook	Heavy Duty / Permanent / Latched		Heavy Duty / Clevis Pinned / Latched		Heavy Duty/Permanent/Latched
Fairlead/Hawse	4-Way Roller				
Remote Control	30' Sealed Handheld				
Weight Installed lbs (kg)	28.2 (12.79)	30.5 (13.8)	32 (14.51)	38.9 (17.6)	32 (14.51)
Weight Shipping lbs (kg)	31.2 (14.15)	33.5 (15.1)	35 (15.87)	40 (18.14)	40 (18.14)
Warranty	Limited Lifetime Warranty - 3 Year Electrical				
UPC	022705000338	022705000345	0227050003315	0227050003049	022705000352
<b>Performance</b>	<b>S3000</b>	<b>S4000</b>	<b>S4000SR</b>	<b>S4000DD</b>	<b>S5000</b>
No Load					
Amps	15	30	30	30	40
Line Speed					
FPM (MPM)	17 (5.1)	21.6 (6.5)			
At Load					
Amps	220	311	111	110	350
Line Speed					
FPM (MPM)	4.5 (1.4)	4.5 (1.4)	10.5 (3.2)	4.5 (1.4)	10.5 (3.2)
<b>Alternate Versions</b>	<b>S3000</b>	<b>S4000</b>	<b>S4000SR</b>	<b>S4000DD</b>	<b>S5000</b>
24VDC	1430300	1440300			1450300

Mounting Bolt Pattern: 2 Hole, 93.7mm on Center

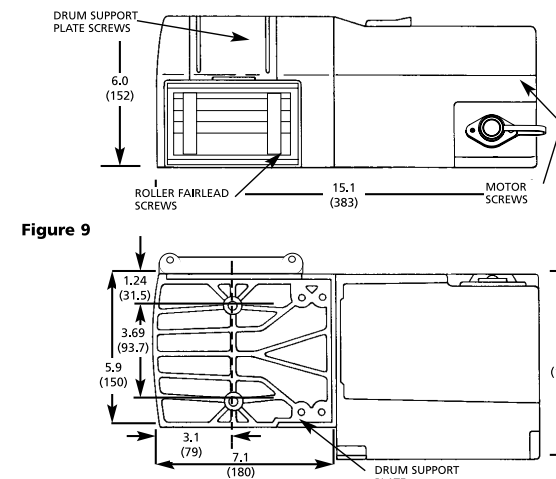

Superwinch Small X-Series, the winch that started it all. Compact and durable, the X line is as popular today as ever. A rugged gearbox and rated line pulls from 2,000 lbs to 4,000 lbs make these winches an economical and reliable choice



**X1**  
P/N 1101 12VDC



The X1 has a rated line pull of 2,000 pounds, a 1.8 hp motor (1.34 kw), differential planetary gearing and dynamic breaking action. Optional Roller Fairlead P/N 1560A

**X2**  
P/N 1201 12VDC

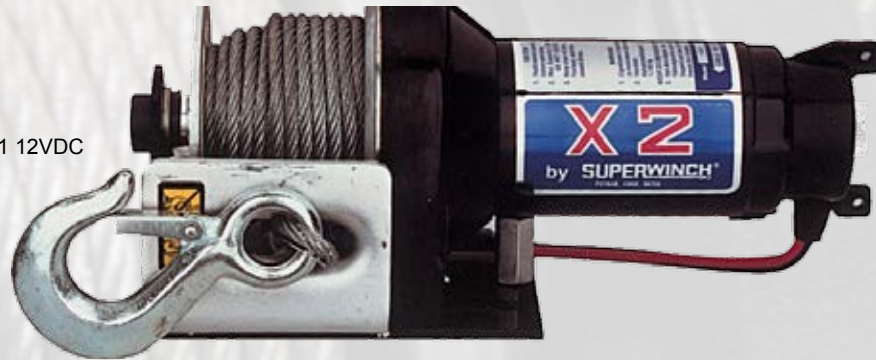

The X2 has a rated line pull of 3,000 pounds, a 1.8 hp motor (1.34 kw), differential planetary gearing and dynamic breaking action. Other features include a wire rope tensioner and a steel hawse fairlead. Optional Roller Fairlead P/N 1560A

**X3F**  
P/N 1307 12VDC



The X3 winch has a rated line pull of 4,000 pounds, a 15' sealed hand-held remote (4.5 m), a 2.0 hp motor (1.5 kw), differential planetary gearing, dynamic breaking action and a pull and turn free-spooling clutch. Other features include a wire rope tensioner and a steel hawse fairlead. Optional Roller Fairlead P/N 1560A



Model	X1	X2	X3F
Part Number	1101	1201	1307
Voltage	12VDC		
Rated Pull lbs (kg)	2,000 (907)	3,000 (1361)	4,000 (1814)
Motor hp (kW)	1.8 (1.34)		2.0 (1.5)
Gearing	Planetary Differential		
Gear Ratio	123:1	148:1	
Solenoid	Circuit Breaker Protected		
Freespool	N/A	Pull and Turn	
Brake	Dynamic		
Rope Length ' (m)	25 (7.6)	40 (12.19)	50 (15.2)
Rope Dia " (mm)	3/16 (4.8)	7/32 (5.6)	
Hook	Permanent/Latched		
Fairlead/Hawse	(see page 40)		
Remote Control	Motor Mounted Switch		Handheld
Weight Installed lbs (kg)	15 (6.8)	19 (8.6)	15 (6.8)
Weight Shipping lbs (kg)	24 (10.8)	22 (9.9)	18 (8.16)
Warranty	Limited One Year Warranty		
UPC	022705011013	022705012010	022705002028
Performance			
No Load			
Amps	30	30	35
Line Speed FPM (MPM)	25.5 (7.8)	27 (8.2)	33 (9.1)
At Load			
Amps	200	223	290
Line Speed FPM (MPM)	7 (2.1)	4.3 (1.3)	3.5 (1.1)
Alternate Versions			
24VDC	X1 1117	X2 1213	X3F 1316

Mounting Bolt Pattern: 2 Hole, 93.7mm on Center

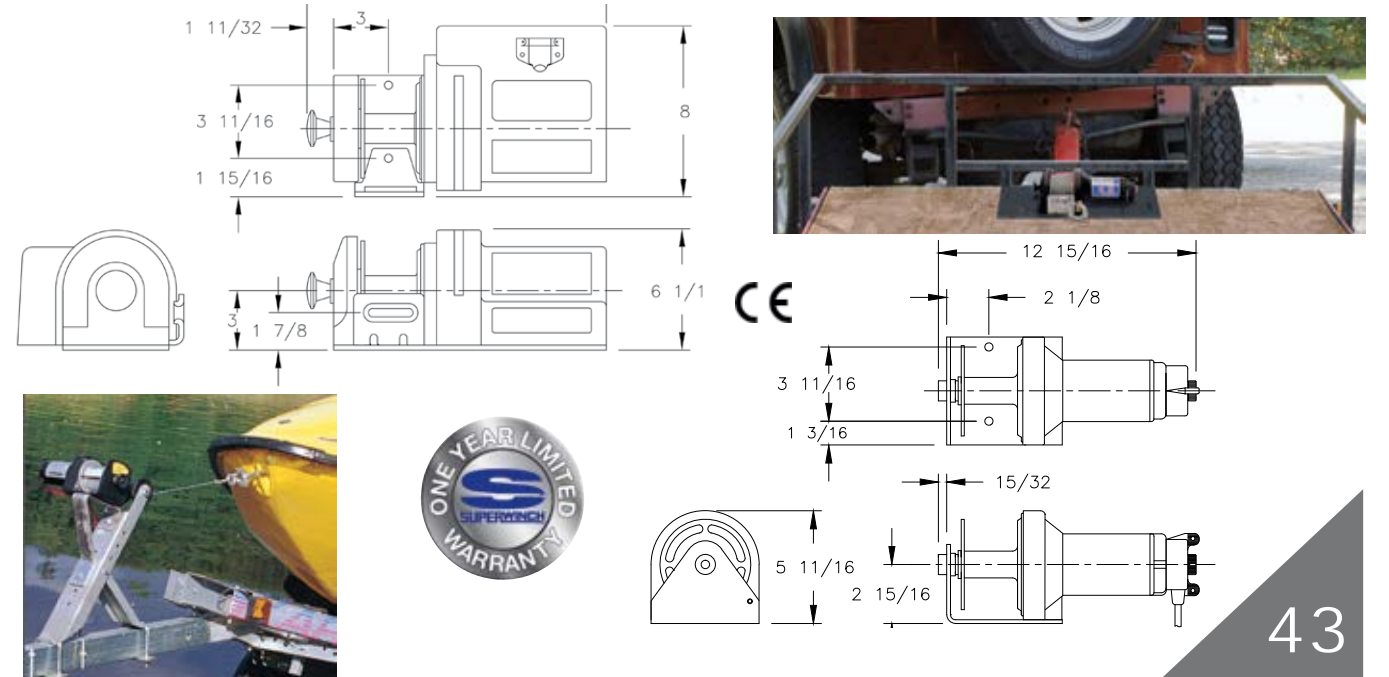



# GP 3000 / LT 2000 / UT 3000

Utility / Multipurpose / Trailer



**LT 2000**  
P/N 1220210



\*NEW CONTROLLER AVAILABLE SUMMER 2014

**NOTE: To be discontinued 2014**

**GP 3000**  
P/N1330200

**GP 3000CE**  
P/N1330222  
(UK/EU)



**UT 3000**  
P/N 1331200



Trailer Hitch adaptor for GP, see page 73 PN2060

# SUPERWINCH®

## Technical Data GP / LT / UT



Model	GP3000 CE	GP3000	LT2000	UT3000
Part Number	1330222	1330200	1220210	1331200
Voltage	12VDC			
Rated Pull lbs (kg)	3,000 (1361)		2,000 (907)	3,000 (1361)
Motor hp (kW)	1.1 (.82)		1.0 (.75)	1.2 (.89)
Gearing	1-Stage Planetary			
Gear Ratio	153:1			
Solenoid	Sealed Submersible Solenoid		Circuit Breaker Protected	
Freespool	Pull and Turn			
Brake	Automatic Mechanical and Dynamic		N/A	Dynamic
Rope Length ' (m)	50 (15.2)		49 (15)	40 (12)
Rope Dia " (mm)	3/16 (4.8)		5/32 (3.9)	3/16 (4.8)
Hook	Permanent	Clevis Pinned	Permanent	Clevis Pinned
Fairlead/Hawse	4-Way Roller Fairlead		N/A	4-Way Fairlead
Remote Control	15' Sealed Handheld		8' Handheld	12' Rubberized
Weight Installed lbs (kg)	16 (7.25)		12 (5.4)	19.5 (8.84)
Weight Shipping lbs (kg)	28 (12.7)		17.4 (7.89)	22.3 (10.11)
Warranty	Limited Lifetime/3-Year Electrical		Limited 1-Year	
UPC	022705001465	022705000321	022705002646	022705002721
<b>Performance</b>				
No Load	Amps	15	10	5
	Line Speed fpm (mpm)	26.9 (8.2)	10 (3.0)	8.5 (2.58)
At Load	Amps	180	100	110
	Line Speed fpm (mpm)	5.0 (1.5)	2.5 (0.8)	2.2 (0.6)

Mounting Bolt Pattern: 2 Hole 79.5mm on Center

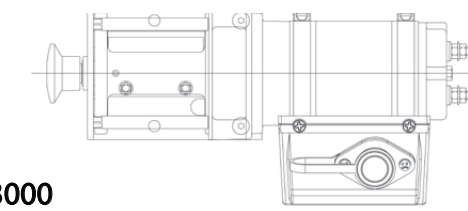
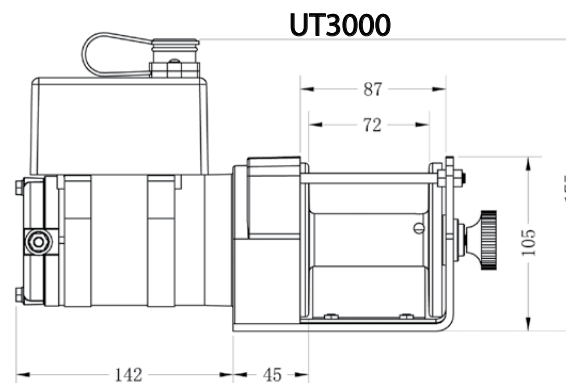
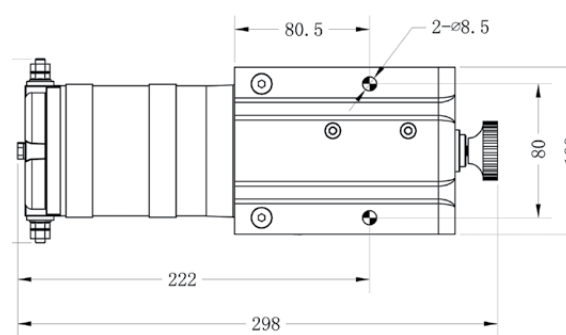

GP3000

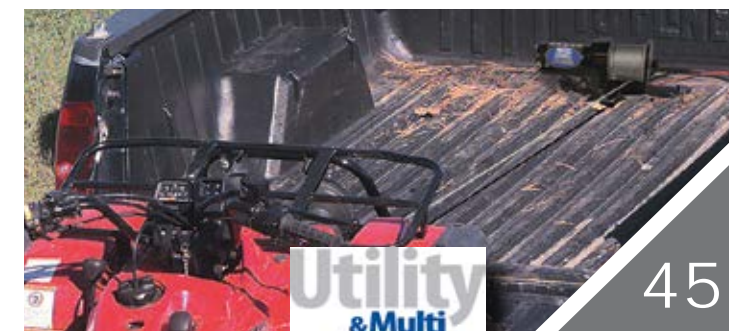
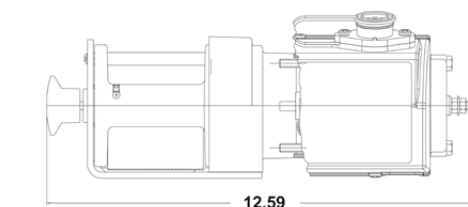
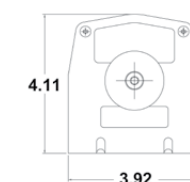

Utility & Multi



# TERRA 25 and 35

ATV / UTV / Side by Side



Designed with the toughest terrains in mind, this series of **ATV** and **Side by Side** winches, with line pull ratings of 2,500, 3,500 and 4,500 lbs, feature rugged all metal 3-stage planetary gear train construction. Longer life, more torque and strong enough to get users out of virtually anything they get into.



- Sealed Heavy Duty Motor

- Heavy Duty Roller Fairlead and Clevis Pin, Latched Hook

- Constructed with Oversized Gears with Unique Bearing Surfaces Lubricated with Synthetic Grease for Long life and High Torque

- Steel Drum specifically designed to withstand the rigor of Synthetic Rope



Terra 25  
P/N 1125220



Terra 35SR  
P/N 1135230

# SUPERWINCH®

## Advantages TERRA SERIES



1. Wider Gears - The Superwinch Terra line features gears that are 2X as wide as the next competitor. This means far better engagement plus longer life.
2. Bigger Motors - Superwinch Terra motors are bigger for one reason: better efficiency. From faster cooling to providing more torque, the Terra motors are the leaders in ATV winches.
3. Designed for Synthetics - With beefed up, welded steel drum tube and flanges and certified quality Dyneema™ rope, only Superwinch Terra is engineered specifically for the unique loads synthetic rope exhibits.
4. Giving You Control - Terra winches come stock with both a 10' sealed hand held remote as well as a sealed handle bar mounted rocker switch. Select a Terra winch and you've got power at your fingertips.



Handlebar remote

Sealed hand-held control

Sealed submersible solenoid

Competition  
Steel drum designed for Synthetic rope

The Industries First Fully Sealed ATV winch

Easy to engage & disengaged ergonomic freespool control

Competition

Rugged all steel over sized gears, with unique Synthetic grease holding bushings

Competition

Competition  
Heavy duty motor, more torque, more power





# TERRA 45

UTV / Side by Side



This is the industry's first truly sealed Utility Terrain Vehicle winch assembly. All seals on the entire winch from the outermost end of the motor to the ergonomic free spool control knob all meet the IP67 rating. Even the handlebar mounted rocker switch, the 10' hand-held remote and the solenoid are sealed and meet this same tough standard which ensures to keep out water, mud, snow and dust.



**Terra 45**  
P/N 1145220



- Limited Lifetime on mechanical parts / 1 Year on the electrical
- Heavy Duty Roller Fairlead or CNC Aluminum Hawse (Synthetic Rope Models) with Heavy Duty, Clevis pin, Latched Hook

**Terra 45SR**  
P/N 1145230



Ergonomic  
Freespool  
Control

# SUPERWINCH®

## Technical Data TERRA SERIES



Model	25	25SR	35	35SR	45	45SR
Part Number	1125220	1125230	1135220	1135230	1145220	1145230
Voltage	12 VDC					
Rated Pull lbs (kg)	2,500 (1134)		3,500 (1588)		4,500 (2041)	
Motor hp (kW)	1.3 (1.0)		1.6 (1.2)			
Gearing	3-Stage Planetary					
Gear Ratio	140:1				191:1	
Solenoid	Sealed Solenoid with Circuit Breaker					
Freespool	Ergonomic Control					
Brake	Mechanical, Automatic, Load Holding					
Rope Length ' (m)	50 (15.2)				55 (45)	50' (15.2)
Rope Dia " (mm)	3/16 (4.8)		13/64 (5.2)	3/16 (4.8)		1/4 (6.5)
Hook	Heavy Duty/Clevis Pinned/Latched					
Fairlead/Hawse	Fairlead	Hawse	Fairlead	Hawse	Fairlead	Hawse
Remote Control	10' Rugged Handheld and Handlebar Switch					
Weight Installed lbs (kg)	18 (8.2)	15 (6.8)	20 (9.1)	17 (7.7)	22 (10)	19 (8.6)
Weight Shipping lbs (kg)	29.5 (13.3)	23.7 (10.7)	30.9 (14.0)	25.2 (11.4)	34 (15.4)	27.9 (12.7)
Warranty	Limited Lifetime Warranty - One Year Electrical					
UPC	022705003421	022705003438	022705003445	022705003452	022705003469	022705003476
Performance	25	25SR	35	35SR	45	45SR
No Load	Amps	25		19		21
	Line Speed fpm (mpm)	25 (7.6)		22.5 (6.9)		15.0 (4.6)
At Load	Amps	162		190		178
	Line Speed fpm (mpm)	9.5 (2.9)		9.3 (2.8)		5.5 (1.7)

Mounting Bolt Pattern: Terra 25, 35 - 3.0" x 4.87" (76mm x 124mm) / Terra 45 - 3.0" x 6.66" (76mm x 169mm)

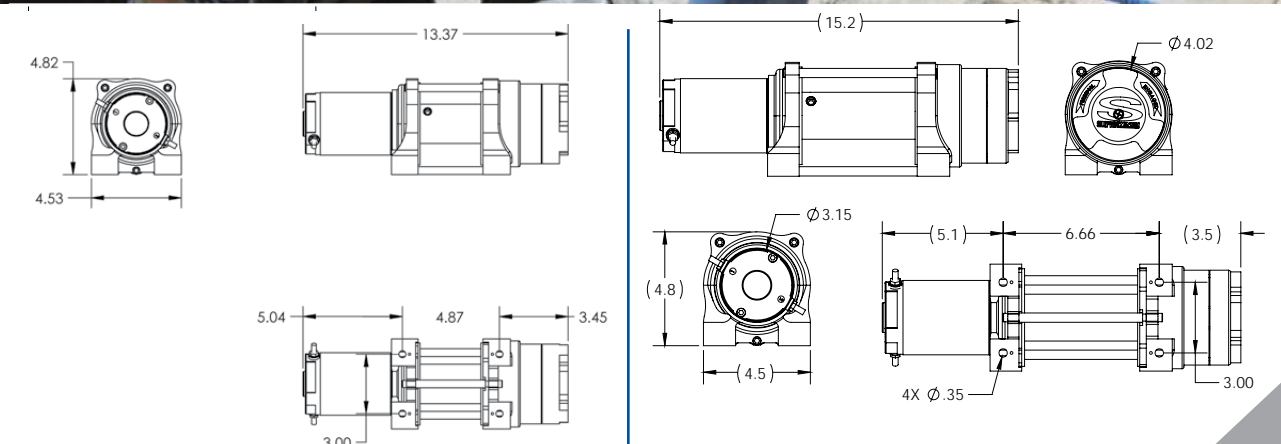

TERRA 25 / 35

TERRA 45



# LT SERIES / WIAB SERIES

ATV / UTV / Side by Side / UTILITY



**Winch-In-A-Bag Plus**  
P/N 1125149



\*NEW CONTROLLER AVAILABLE, SUMMER 2014



**Winch-In-A-Bag**  
P/N 1120149

LT 3000 ATV P/N 1130220



\*NEW CONTROLLER AVAILABLE, SUMMER 2014



LT 4000 ATV P/N 1140220



LT 2000 ATV P/N 1120210



## Technical Data LT / WIAB



Model	LT2000ATV	WIAB	WIAB+	LT3000ATV
Part Number	1120210	1120149	1125149	1130220
Voltage	12VDC			
Rated Pull lbs (kg)	2,000 (907)		2,500 (1134)	3,000 (1361)
Motor hp (kW)	1.0 (.75)		1.1 (.82)	1.2 (.89)
Gearing	Differential Planetary			3-Stage Planetary
Gear Ratio	153:1			136:1
Breaker	Circuit Breaker Protected			
Freespool	Pull and Turn		Ergo Clutch Control	
Brake	Dynamic	N/A		Automatic Mechanical Dynamic
Rope Length ' (m)	49 (14.9)		40 (12.0)	50 (15)
Rope Dia " (mm)	5/32 (3.9)		3/16 (4.8)	
Hook	Permanent		Heavy Duty/Clevis Pinned/Latched	
Fairlead/Hawse	Fairlead	Teflon® Guide		Fairlead
Remote Control	Hbar Rocker	8' Handheld		12' Handheld
Weight Installed lbs (kg)	14.2 (6.44)	16.15 (7.32)	18.15 (8.23)	20 (9.0)
Weight Shipping lbs (kg)	18.75 (8.5)	24 (10.88)	26.9 (12.2)	27 (12.24)
Warranty	Limited One Year Warranty			Limited 2 Year
UPC	022705002653	022705003056	022705003155	022705003162

Performance		LT2000ATV	LT3000ATV
No Load	Amps	10	15
	Line Speed FPM (MPM)	10 (3.0)	23 (7.0)
At Load	Amps	100	180
	Line Speed FPM (MPM)	2.5 (0.8)	4.0 (1.2)



Mounting Bolt Pattern: LT 2000 ATV  
2 Hole, 3.15" (80mm) on Center

Mounting Bolt Pattern: LT 3000 ATV  
2 Hole, 3.0" x 4.87" (76mm x 124mm)

Winch-In-A-Bag (Plus), Mount not required





# C1000 CRANE WINCHES

Utility / Multipurpose / Material Handling



## COMMERCIAL PLANETARY WINCHES

- Earning the 5:1 Safety Factor rating, our C1000 is the right winch to safely move materials.
- Rated to 1,000 pounds (454 kg.) steel spring tension plate, power “in and out” and full-load mechanical brake ensure secure, easy and smooth operation.
- 5:1 Safety Factor ensures operator safety while lifting and moving loads.
- Differential planetary gear design delivers power and durability.
- 15’ switch on a rubber cord is included P/N 03002
- Sturdy 1.3 hp, 12VDC and 24VDC motor includes weather resistant cover (except P/N 03001).



**NOTE: The C1000 winch has a 5:1 safety factor.**

Note; crane winches do not include wire rope

Never use a winch to lift or move people

**C1000**  
P/N 03002 12VDC  
(w/ 15' Remote)



**C1000**  
P/N 03003 12VDC  
(Remote mount solenoid)



**C1000**  
P/N 03001 12VDC  
(NO Remote)



# SUPERWINCH®

## Technical Data C1000 CRANE WINCHES



Model	C1000	C1000	C1000
Part Number	03002	03010	03001
Voltage	12VDC	24VDC	12VDC
Rated Pull lbs (kg)	1,000 (454)		
Motor hp (kW)	1.3 (.96)		
Gearing	Differential Planetary		
Gear Ratio	159:1		
Breaker	Circuit Breaker Protected		
Freespool	N/A		
Brake	Automatic Mechanical and Dynamic		
Rope Length ' (m)	N/A		
Rope Dia " (mm)	Optional P/N 1577A		
Hook	N/A		
Fairlead	4-Way Roller		
Remote Control	N/A		
Weight Installed lbs (kg)	26.8 (12.15)		29 (13.15)
Weight Shipping lbs (kg)	29.8 (13.51)		32.0 (14.51)
Warranty	Limited One Year Warranty		
UPC	022705300209		02270500185
Performance	C1000	C1000	C1000
No Load	Amps	30	
	Line Speed		
	FPM (MPM)	19.5 (5.9)	
At Load	Amps	80	
	Line Speed		
	FPM (MPM)	14.7 (4.5)	

Mounting Bolt Pattern: 2 Hole, 3.69" (93.7mm) on center

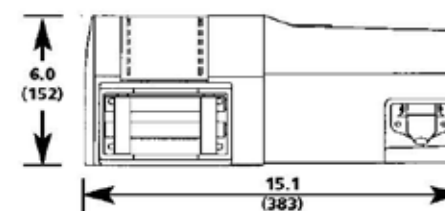

( C-SERIES )

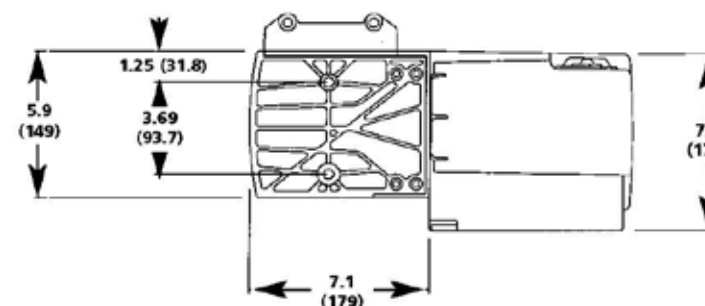

Utility  
& Multi





# SAC 1000 / AC 1000 / AC 1500

/ Utility / Multipurpose / Material Handling



AC 1000  
P/N 1401

SAC 1000  
P/N 01002 with Hawse  
P/N 01001 with Roller Fairlead

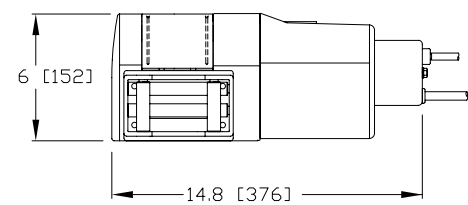

AC 1500  
P/N 1715000

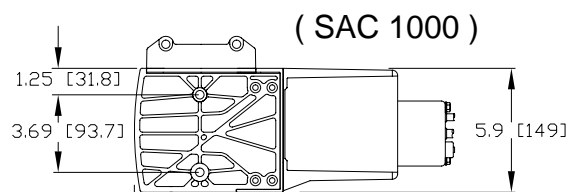

(SAC 1000)

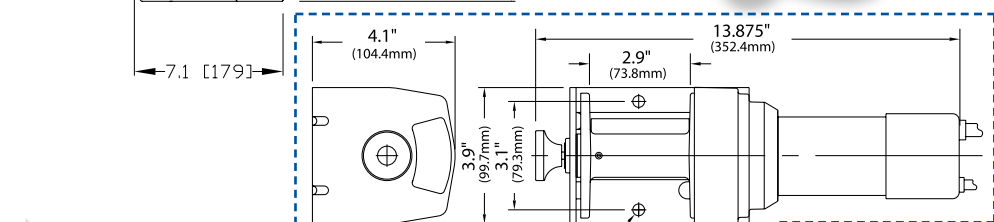

(AC 1000)

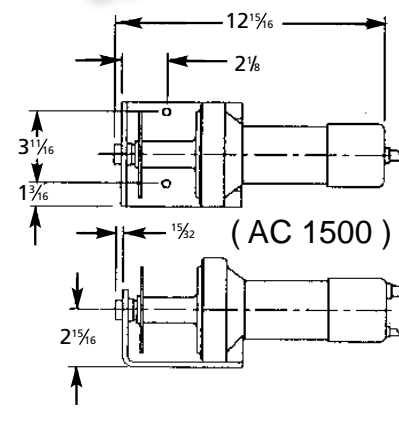

(AC 1500)



NEVER USE A WINCH TO SUSPEND A LOAD, NEVER USE A WINCH TO LIFT OR MOVE PEOPLE



# AC 2000 / AC 3000

Utility / Multipurpose / Material Handling



Model	AC1000	SAC1000	AC1500	AC2000	AC3000
Part Number	1401	1001	1002	1715000	1730000
Voltage	115VAC				
Hz	50/60 (Excludes UK/EU Markets)				
Rated Pull lbs (kg)	1,000 (454)	1,000 (454)	1,500 (680)	2,000 (907)	3,000 (1361)
Motor hp (kW)	0.6 (45)			.75 (.56)	1.0 (.75)
Gearing	1-Stage Planetary				
Gear Ratio	123:1	159:1	153:1	253:1	
Breaker	Breaker/Resettable Push Button	Breaker		Breaker/Resettable Push Button	
Freespool	N/A	Lever Control	N/A	Pull and Turn	1/4 Turn Clutch
Brake	Dynamic	Mechanical/Dynamic			100% Automatic
Rope Length ' (m)	45 (13.7)	50 (15.2)		35 (10.6)	100 (30.5)
Rope Dia " (mm)	5/32 (3.9)	3/16 (4.8)			5/16 (7.9)
Hook	Permanent/Latched			Clevis Pinned / Latch	
Fairlead/Hawse	N/A	Roller	Hawse	Optional P/N 1560C	N/A
Remote Control	6' Handheld Pendant			Drum Switch	
Weight Installed lbs (kg)	18 (8)	25.4 (11.5)	27.6 (12.5)	18 (8)	76 (34.5)
Weight Shipping lbs (kg)	21 (9.5)	28.4 (12.8)	30.6 (13.8)	22 (9.9)	83 (37.6)
Warranty	Limited One Year Warranty			Limited Lifetime Warranty	
UPC	022705014014	022705100106	022705100205	22705002141	22705017237
Performance	AC1000	SAC1000	AC1500	AC2000	AC3000
No Load					
Amps	4.3	3		1.2	6.6
Line Speed					
FPM (MPM)	23.0 (7.0)	13.8 (4.2)		15.5 (4.7)	10.5 (3.2)
At Load					
Amps	10			11.5	
Line Speed					
FPM (MPM)	9.2 (2.8)	13.0 (4.0)	7.2 (2.2)	10.0 (3.0)	
Alternate Versions	AC1000	SAC1000	AC1500	AC2000	AC3000
24VDC			1213	1215	1316

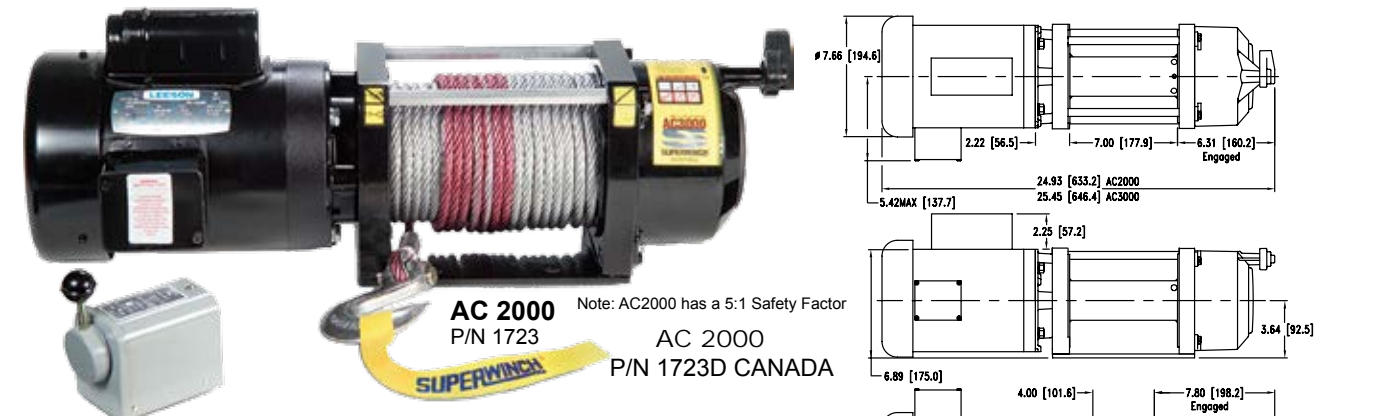

AC 2000  
P/N 1723  
AC 2000  
P/N 1723D CANADA

Note: AC2000 has a 5:1 Safety Factor



AC 3000  
P/N 1730000  
AC 3000  
1730001 Canada



(AC2000 / AC3000)  
Mounting Bolt Pattern: SAC 1000  
2 Hole, 3.69" (94mm) on Center  
Mounting Bolt Pattern: AC 1000  
2 Hole, 3.69" (94mm) on Center  
Mounting Bolt Pattern: AC 1500  
2 Hole, 3.13" (79.5mm) on Center  
Mounting Bolt Pattern: AC 2000 / 3000  
4 Hole, 4.0" x 4.45" (101.6mm x 114.3mm)



NEVER USE A WINCH TO SUSPEND A LOAD, NEVER USE A WINCH TO LIFT OR MOVE PEOPLE



# POWER DRIVES

Commercial Duty Worm Gear Drives



- Superwinch Power Drives supply reliable power anywhere automation can provide a more efficient method of executing tasks.
- Safely automating the movement of many types of home, commercial, and industrial equipment, our Power Drives are lightweight, self-contained and ready to plug in.
- All Superwinch units carry both cross pin hole and keyway mating with rotary or linear applications.
- From backyards to barns, stadiums and shipyards, Superwinch power is there.



Superwinch Power Drive Advantage

- Over 4 million are already on the job whenever automation can provide safer, more efficient operation.
- Drives are available with single output, 12VDC and 24VDC motors and either 60:1 or 90:1 ratio.
- All Power Drives include four magnet shoes for greater efficiency and longer runs.
- Each Power Drive is equipped with a permanent magnet motor. This means that the Power Drive must be used for only short periods of time and allowed to cool down.



# SUPERWINCH®

Technical Data  
**POWER DRIVES**



Model	716527	716627	719630	716727	719527	719627	719727	716537	719537	719637	
Output Shaft	Single Output Shaft										
Voltage	12VDC			24VDC			12VDC			24VDC	
Torque inch lbs	750	1,040	1,125	1,200	790	1,125	1,200	750	790	1,125	
Motor hp (kW)	1.3 (.97)	1.8 (1.34)		2.1 (1.57)	1.3 (.97)	1.8 (1.34)	2.1 (1.57)	1.3 (.97)	1.8 (1.34)		
Gearing	Worm Gearset										
Gear Ratio	60:1		90:1	60:1	90:1		60:1	90:1			
Warranty	Limited life Time - One Year Electrical - Three Year Gearbox										

The following performance data is shown to provide a guideline of what speed and current are expected at no load and at rated torque for your Power Drive.

Performance is strongly dependent on voltage applied to the motor. If long lengths of small diameter wire are used, performance will be severely limited due to the voltage drop caused by the wire. The voltage at the motor should be verified to be at or greater than the rated voltage specified in Table 2; this will allow the unit to achieve the performance values shown here. It is also important to verify that adequate current is available to achieve these performance results.

Table 2

### DC POWER DRIVE MODELS

Power Drive #'s	No Load					Rated Torque							
	CW @ Output Shaft		CCW @ Output Shaft		Rated Torque (in-lb)	CW @ Output Shaft				CCW @ Output Shaft			
	RPM	Current (A)	RPM	Current (A)		With 10' Total of 8 AWG (6 AWG for XXX72X)		12V Across Motor - 12V Models 24V Across Motor - 24V Models		With 10' Total of 8 AWG (6 AWG for XXX72X)		12V Across Motor - 12V Models 24V Across Motor - 24V Models	
716527	90	25	73	36	750	38	170	51	145	37	190	39	190
716627	87	26	73	29	1040	35	225	48	202	30	260	54	230
716537	90	15	78	17	750	51	70	51	70	45	95	39	105
719527	66	21	57	21	790	34	130	42	117	28	165	36	155
719627	60	17	57	24	1125	28	200	39	205	25	250	42	258
719537	60	14	54	17	790	39	62	42	58	36	79	36	79
719637, 719630	60	15	54	16	1125	32	100	32	105	28	116	27	134
716727	96	30	78	30	1200	33	245	54	245	18	330	27	300
719727	64	27	57	28	1200	24	240	36	200	12	330	21	320

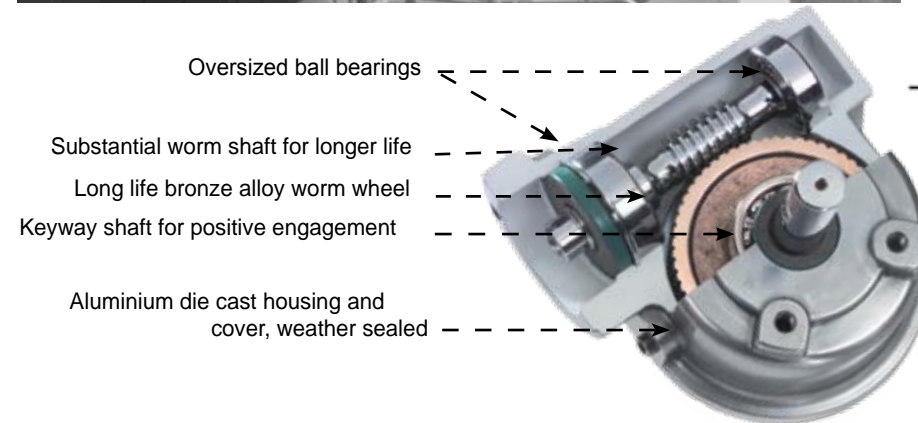
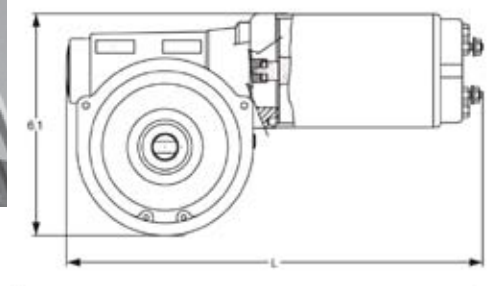

- Oversized ball bearings
- Substantial worm shaft for longer life
- Long life bronze alloy worm wheel
- Keyway shaft for positive engagement
- Aluminium die cast housing and cover, weather sealed

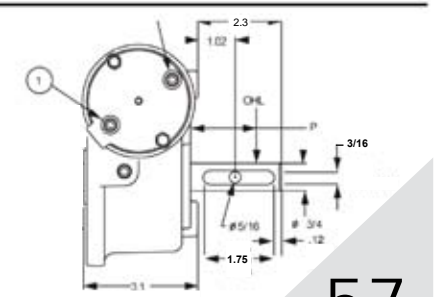



**SEPSON**

Heavy Vehicle Recovery / Military / Oil Field / Mining



Made in Sweden

Taking serious winches to new heights, Superwinch has partnered with Sepson, manufacturer of remarkable military-grade winches. Designed and manufactured in Vasbro, Sweden, Sepson winches offer extreme reliability under all conditions, from tropical heat to arctic cold. If serious winching is your specialty Sepson is your winch.

H400



With Sepmatic, Sepson has upgraded a number of Sepdurance winches to include the unique Sepson integrated spooling attachment. It will eliminate nesting and significantly increase the rope life and thus reduce operating costs and improve safety. The Sepson design of the spooling attachment drives it with a cog wheel mounted on the side of the rope under all conditions, without adding proprietary parts. It is another typical example of the Sepson design criteria that combine efficiency with simplicity. Five basic Sepdurance winches can be advanced to Sepmatic status by adding the spooling attachment while they maintain their own characteristics within the Sepson design family. They range in capacity from 50 kN to 450 kN and will substantially improve the speed and performance of the winching operation under the most difficult conditions.



H100S

Sepdurance winches are made with line pulling forces from 38 kN to 450 kN and the robust construction combined with careful and deliberate design, provide both ease of assembly and mounting. Also included in the Sepdurance range are two winches particularly engineered for side mounting (H100S). The compact design which leads to a small footprint, are two of the deciding features that have made manufacturers in countries world wide chose the Sepdurane winches for all critical purposes, both military and commercial.



Technical Data

**SEPSON**



Made in Sweden

Model	H400	H100S
Rated Pull lbs (kN)	100,000 (450)	27,000 (120)
Motor	High Torque	
Gearing	3-Stage Planetary	Planetary Plus Spur Gear
Gear Ratio	50:1	31.3:1
Max Oil Pressure psi (BAR)	3,000 (200)	
Max Oil Flow gpm (l/min)	18 (70)	15 (60)
Brake	Automatic/Load Holding (outside of drum)	
Recommended Rope Length ' (m)	262 (80)	196 (60)
Recommended Rope Dia " (mm)	1 (25.4)	5/8 (16)
Auto Spooling Device	Optional	
Constant Pull Technology	Optional	
Mounting Pattern	Foot Mount	Various
Weight Installed lbs (kg)	1,785 (810)	473 (215)
Warranty	Limited 2-Year Warranty	
Performance	H400	H100S
	Low Auto 2 Speed	
Bottom Layer FPM (MPM)	8.2 (2.5)	16.4 (5.0)
Top Layer FPM (MPM)	13 (4.0)	31 (9.5)
	High Auto 2 Speed	
Bottom Layer FPM (MPM)	20 (6.0)	
Top Layer FPM (MPM)	30 (9.0)	

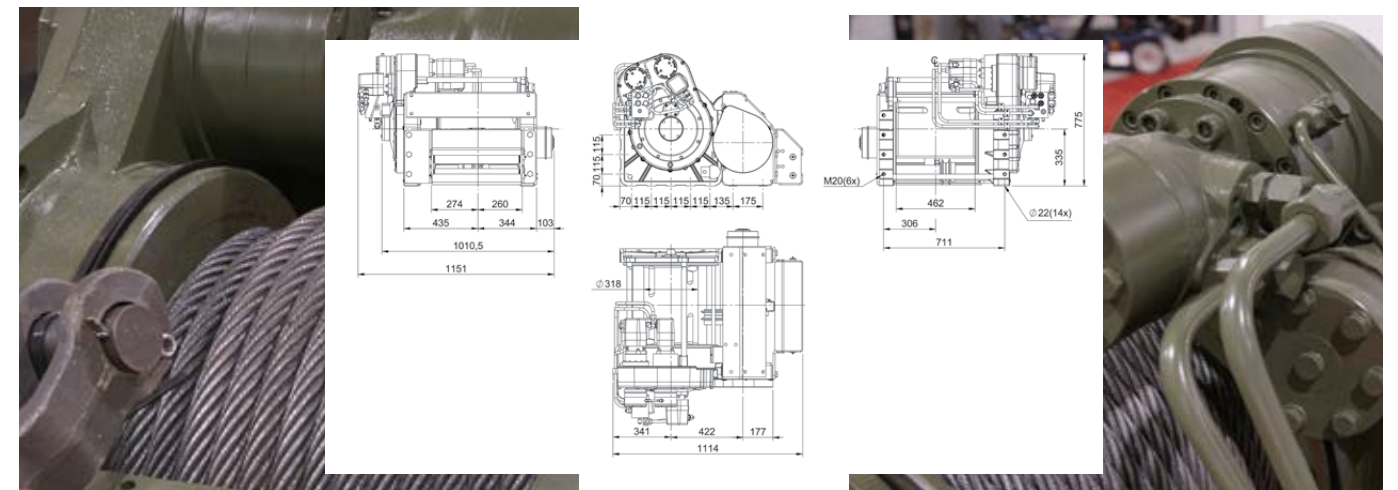



The Superwinch HP line of hydraulic winches provides you with a continuous duty solution to your winching requirements. They were designed with the toughest commercial/industrial applications in mind and engineered to ensure total reliability during recovery/winching operations.



- 5050 (UK/EU) H8P - Standard Drum/Manual Freespool
- 5050A (North America) H8P - Standard Drum/Manual Freespool
- 5060 (UK/EU) H8P - Long Drum/Manual Freespool
- 5060A (North America) H8P - Long Drum/Manual Freespool
- 5050S (UK/EU) H8P - Std Drum w/SuperBlock
- 5060S (UK/EU) H8P - Long Drum w/SuperBlock
- 5156A (North America) H8P - Long Drum w/LCV
- 5170 (UK/EU) H10P - Long Drum/Manual Freespool
- 5170A (North America) H10P - Long Drum/Manual Freespool
- 5178A (North America) H10P - Long Drum/Manual Freespool

Available in a full range of planetary drives with capabilities from 8,000 to 10,000 pounds: many of our hydraulic winches are rated to SAE J706 standards and are CE certified. Most models are available with manual or pneumatic free-spooling, load holding brakes, and LCV (Load Control Valves) to give you precise control of your load. Superwinch PRO Series winches conform to EN 14492-1 Power Driven Winches and Machinery Directive 2006/42/E.



- 5050PRO (UK/EU) H8P - Standard Drum/Manual Freespool
- 5060PRO (UK/EU) H8P - Long Drum/Manual Freespool
- 5170PRO (UK/EU) H10P - Standard Drum/Manual Freespool
- 5172PRO (UK/EU) H10P - Long Drum/Manual Freespool

The HP Series winches are reversible with 'power-in' and 'power-out' via a directional control valve mounted on the vehicle. The standard unit is supplied with counter-clockwise drum rotation on 'winch-in' when viewed from the gearbox end. The winch can be used in both 'over-wound' and 'under-wound' conditions.

H8P Winch Installation

WINCH:	DIMENSION: mm									
	A	B	C	D	E	F	G	H	I	J
SHORT DRUM	300	190	591	229	298,5	311	299	292	155,5	114,5
LONG DRUM	330	253	654	292	361,5	374	330	324	187	146

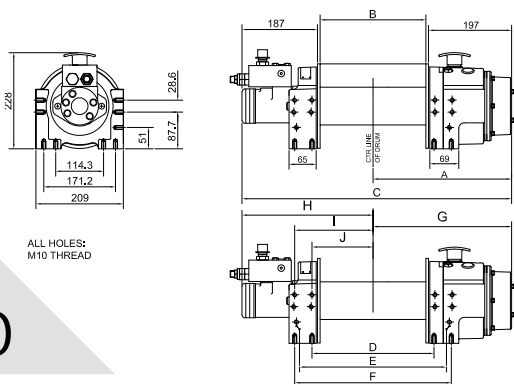

ALL HOLES:  
M10 THREAD

H10P Winch Installation

WINCH:	DIMENSION: mm									
	A	B	C	D	E	F	G	H	I	J
SHORT DRUM	300	190	601	229	298,5	311	299	302	155,5	114,5
LONG DRUM	330	253	664	292	361,5	374	330	334	187	146

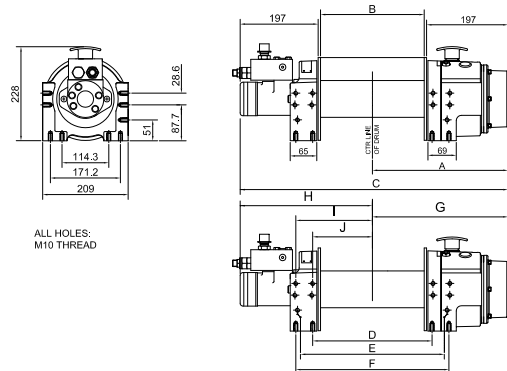

ALL HOLES:  
M10 THREAD



The Superwinch HP line of hydraulic winches provides you with a continuous duty solution to your winching requirements. They were designed with the toughest commercial/industrial applications in mind and engineered to ensure total reliability during recovery/winching operations.



H11P / H12P / HP13P

Available in a full range of planetary drives with capabilities from 11,000 to 15,000 pounds: many of our hydraulic winches are rated to SAE J706 standards and are CE certified. Most models are available with manual or pneumatic free-spooling, load holding brakes, and LCV (Load Control Valves) to give you precise control of your load. Superwinch PRO Series winches conform to EN 14492-1 Power Driven Winches and Machinery Directive 2006/42/E.



H14P / H15P

The winch is equipped with an adjustable free-spooling damper to help alleviate the possibility of wire rope over-run on the drum. The automatic disc brake is housed in the planetary gearbox. The brake will activate automatically to prevent the load from causing the winch to 'back-drive'. The brake itself is self adjusting for wear and is oil immersed for optimum heat dissipation. The brake linings are of high performance non-asbestos material.

H11P / H13P / H15P

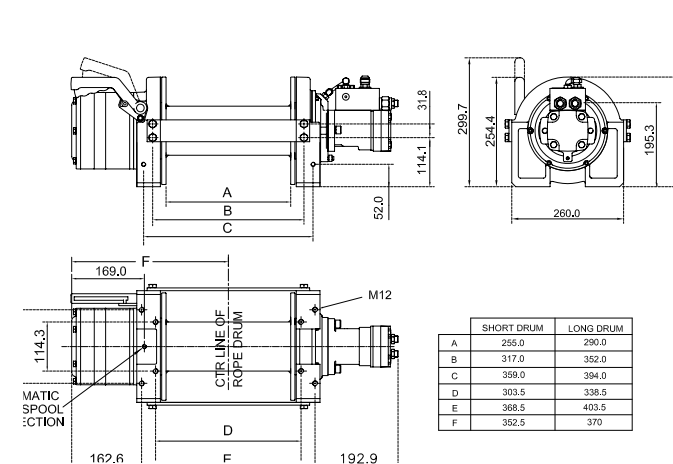

	SHORT DRUM	LONG DRUM
A	255,0	290,0
B	317,0	352,0
C	359,0	394,0
D	303,5	338,5
E	368,5	403,5
F	352,5	370

H11P





H20P  
H25P  
H30P



H45P

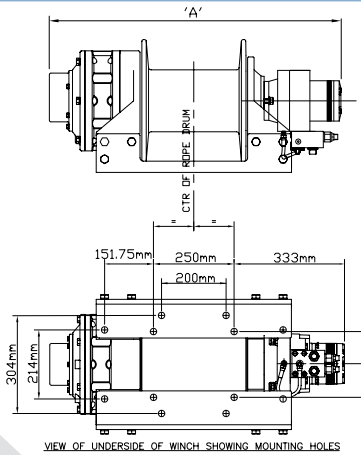

H20-30P

MODEL	DIM "A"	
	FREEPOOL TYPE	PNEUMATIC
H20	927.0	892.0
H25	929.5	894.5
H30	933.0	898.0

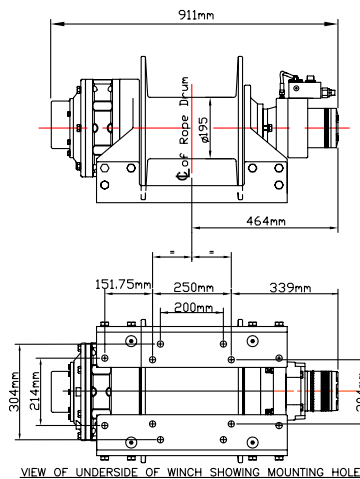

H45P winch

ALL FIXING BOLTS M16  
8.8 GRADE OR HIGHER

Model	H8P (USA)	H8-PRO	H10P (USA)	H10-PRO	H12P	H14P	H15P (USA)	H20P (USA)	H25P (USA)	H30P (USA)	H45P
Part Number	5050A	5050PRO	5170A	5170PRO	5320S	5330S	5374	5440M	5450M	5460M	654002
EN14492 Compliant	No	Yes	No	Yes	No	No	No	No	No	No	No
Rated Pull lbs (kg)	8,000 (3630)	7,848 (3560)	10,000 (4540)	9,479 (4300)	12,000 (5,450)	14,000 (6,550)	15,000 (6800)	20,000 (9080)	25,000 (11340)	30,000 (13610)	45,000 (20412)
Hydraulic Driven	High Torque										
Gearing	2-Stage Planetary				2-Stage Planetary Differential			2-Stage Planetary			
Gear Ratio	16:1				21:1			36:1			
Max Oil Pressure psi (kg/cm <sup>2</sup> )	1,800 (124.13)	2,175 (150)	1,700 (117.24)	1,740 (120)	2,000 (137.9)			2,500 (172.41)		3,000 (207)	
Max Oil Flow gpm (lpm)	15 (57)	15.8 (60)	15 (57)	15.8 (60)	15 (57)			20 (75)		25.1 (95)	
Brake	Mechanical, Multi-Disc										
Recommended Rope Length 'm'	75 (23)	88.5 (27)	75 (23)	65 (20)	75 (23)			238 (72.5)	167 (51)	160 (48.7)	197 (60)
Recommended Rope Dia " (mm)	3/8 (9.5)		7/16 (11)		1/2 (13)			5/8 (16)	11/16 (17.4)	3/4 (20)	
Freespool	Manual (For Pneumatic Option, See Part Number Below)										
Weight Installed lbs (kg)	84 (38)	88 (40)	84 (38)	88 (40)	138 (62.5)			463 (210)		496 (225)	
Weight Shipping lbs (kg)	92 (41.73)		92 (41.73)		157 (70)			485 (220)		518 (235)	
Warranty	Limited One Year Warranty										
UPC	022705505017		022705517010		022705503648	022705503718	022705503747	022705544923	022705545020	022705546027	
Performance											
No Load Line Speed FPM (MPM)	40 (13.8)	48 (14.7)	30 (9.4)	32.8 (10)	38 (11.58)	30 (9.14)	27 (8.22)	34 (10.3)	28 (8.5)	27 (8.22)	21.6 (6.6)
Alternate Version Part Numbers											
Long Drum	5060A (USA)	5060PRO		5172PRO	□□□□S	□□□□S	5376				
Pneumatic Freespool							5375	5440B (USA)	5450B (USA)	5460B (USA)	654001







The Superwinch HW line of hydraulic winches provides you with a high order duty cycle solution to your winching requirements. They were designed with the toughest commercial/industrial applications in mind and engineered to ensure total reliability during recovery/winching operations.

H9W



The Superwinch HW Series - heavy duty, high quality worm drive hydraulic winches, designed to perform in a wide range of applications. Its compact size and robust construction includes heavy duty, steel centered aluminum bronze worm wheel gearbox and case hardened precision ground worm for optimum reliability. Worm set brake for substantial back-drive resistance powered by a rugged, high torque motor with proven reliability. Heavy duty fabricated steel drum assembly mounted on maintenance-free plain bearings allows rapid rope pay out via the free spooling manual release.



H14W



H14 PRO



H14W

Superwinch PRO Series winches conform to EN 14492-1 Power Driven Winches and Machinery Directive 2006/42/E. PRO specs include but not limited to 10:1 D:D ratio rope drum with wire rope fixing via twin-hole safety feature, Load Limiter performed by hydraulic relief valve in vehicle hydraulic system, (supplied by winch installer) and unique labeling for rating plate showing with 1st layer and 4th layer figures, decibel label and fairlead warning label.

Model	H9W	H9W PRO 24.5kN	H9W PRO 24.5kN STD.	H10W	H14W	H14 PRO 6.02 TONNE
Part Number	8588A (USA)	8569PRO short	8588PRO	7085A (USA)	7080A (USA)	7080PRO
EN14492 Complaint	No	Yes		No		Yes
Rated Pull lbs (kg)	9,000 (4082)	5,507 (2500)		10,000 (4535)	14,000 (6350)	13,271 (6020)
Hydraulic Drive	High Torque					
Gearing	Worm Gear Set					
Gear Ratio	54:1			48:1		
Max Oil Pressure psi (bar) kg/cm <sup>2</sup>	1,800 (124) 126.58			2,050 (140)		
Max Oil Flow gpm (lpm)	12 (45)	15 (57)		15.8 (60)		
Freespool	Manual Release Lever					
Brake	Irreversible Worm Set, Full Load Holding					
Recommended Rope Length ' (m)	100 (30)	75 (23)	100 (30)	129 (39)	100 (30)	
Recommended Rope Dia " (mm)	3/8 (10)	5/16 (8)		7/16 (11)	1/2 (13)	
Weight Installed lbs (kg)	62.8 (28.5)	61.7 (28)	62.8 (28.5)	112 (51)		112 (51)
Weight Shipping lbs (kg)	66 (30)			123 (56)		
Warranty	Limited One Year Warranty					
UPC	022705858816			022705708012	02270570802	
<b>Performance</b>						
No Load Line Speed FPM (MPM)	24 (7.3)	15.1 (4.63)		16 (4.8)	10 (3)	11.8 (3.6)

Available in a full range of worm drives with capabilities from 9,000 to 14,000 pounds. Many of our hydraulic winches are rated to SAE J706 standards and are CE certified. Most models are available with manual free-spooling, irreversible self locking worm-wheel action, full load-holding brake to give you precise control of your load.

Superwinch PRO Series winches conform to EN 14492-1 Power Driven Winches and Machinery Directive 2006/42/E. PRO specs include but not limited to 10:1 D:D ratio rope drum with wire rope fixing via twin-hole safety feature, Load Limiter performed by hydraulic relief valve in vehicle hydraulic system, (supplied by winch installer) and unique labeling rating plate showing 1st layer and 4th layer figures, decibel label and fairlead warning label.

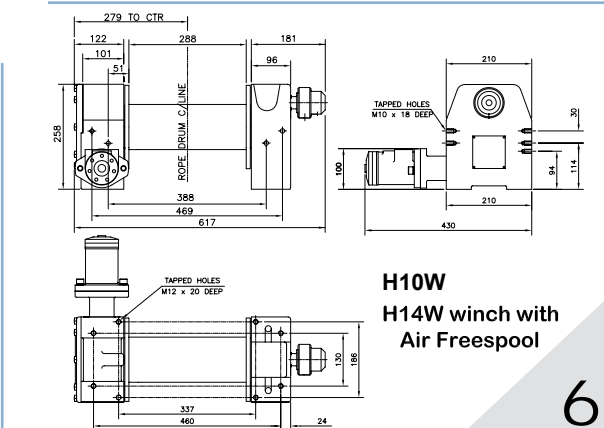
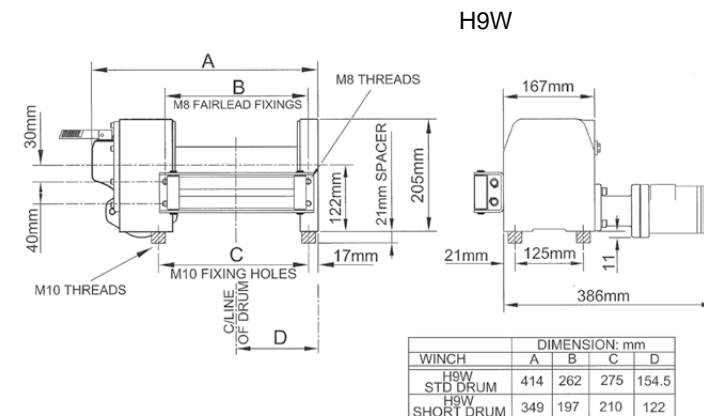

# PORTABLE TALON WINCH KIT



A quick, portable, removable winch cradle combination kit. Includes everything needed for fast, vehicle multi-location winching.



Complete Kit  
Part Number:  
20501695210



Kit includes the following items:



P/N 1695210 Talon 9.5i  
(Talon Performance Series)



P/N 2050 Large Cradle  
(removable portable)



P/N 2007 5' Winch Wiring Kit  
(Quick re-release connectors)



P/N 2008 25' Winch Wire Kit

Increase functionality for emergency vehicles, work trucks and trailers.



# PORTABLE CRADLE ASSEMBLY



Cradle Mount - A Winch, Cradle, plus Receiver, System. The Portable Front and Rear Mounting Solution.



Easy on,  
Easy off  
Installation!

(winch not included)



Enjoy the flexibility the Superwinch Cradle can bring to your winching experience. Move winches from vehicle to vehicle, from the vehicle's front to rear (with front 2" class III receiver hitch) or just conveniently and completely remove the winch from the vehicle.

Bolt a winch to the Cradle and you're ready to simply place the mount into the receiver and pin. You're now ready to roll on cars, side by sides, pickups, trucks, vans and RVs.

The Superwinch Cradle mount is painstakingly crafted to strict quality standards and is comprised of high strength steel. The cradle handles the maximum hitch rating of line pull for effective winching.



Cradle Mounts have installation and safety advantages others don't have.

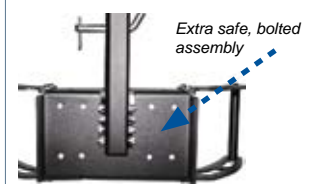

#2055 Small Cradle  
(Fits- X3, S5000, S4000, S3000)



#2050 Large Cradle  
(Fits 10" x 4.5" bolt pattern winches up to 9,500 lbs. capacity)

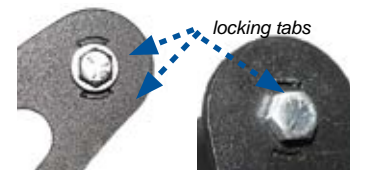

(Check [www.superwinch.com](http://www.superwinch.com) for front receiver kits)



NOTE: TERRA 45 and UTV 4000 are not compatible with these mount plates - contact Superwinch for more details.

ARTIC CAT	YEAR	SW PART #
1000 THUNDERCAT	08-11	2202873
700 4X4 (ALL including V2,H1)	07-11	2202873
650 4X4 (ALL including V2,H1, TRV,TBX)	05-10	2202873
650 4X4 V2	2004	2202380
550 4X4 (Including TRV)	09-11	2202873
500 4X4 (ALL Except 05 TRV)	05-09	2202873
500 4X4 TRV 2-UP	2005	2202380
500 4X4 (ALL Including TBX/TRV)	02-04	2202380
500 4X4 (ALL)	99-01	2202350
454 4X4 BEAR CAT	96-98	2202350
450 4X4 (Including TRV)	10-11	2202873
400 4X4 (ALL Including TBX/TRV)	06-10	2202873
400 4X4 (ALL Including TBX/TRV)	02-05	2202380
400 4X4	98-01	2202350
3754X4 AUTOMATIC	2002	2202380
366 4X4	08-09	2202897
300 4X4	02-05	2202380
300 4X4	98-01	2202350
250 2x4 / 4X4	2001	2202350
650 & 700 PROWLER 4X4 or H1 XTX	06-08	2202892

CAN-AM/BOMBARDIER	YEAR	SW PART #
800 OUTLANDER 4X4	06-11	2202893
800 OUTLANDER MAX 2-UP	06-11	2202893
650 OUTLANDER 4X4	06-11	2202893
650 OUTLANDER 4X4 MAX 2-UP	06-11	2202893
500 OUTLANDER MAX 4X4	07-11	2202893
500 OUTLANDER 4X4	07-11	2202893
400 OUTLANDER MAX 2-UP	04-11	2202865
400 OUTLANDER 4X4	03-11	2202865
330 OUTLANDER 4X4	04-05	2202865
COMMANDER 800 / 1000	11-12	2202913

HONDA	YEAR	SW PART #
TRX 650/680 RINCON (ALL)	03-12	2202867
TRX 500 FOREMAN	2012	2202910
TRX 500 FOREMAN / RUBICON	09-11	2202898
TRX 500 FORMAN / RUBICON (ALL)	07-08	2202878
TRX 500 FOREMAN E.S.	05-06	2202877
TRX 500 FOREMAN / RUBICON &GPSCAPE	05-06	2202879
TRX 500 FOREMAN / RUBICON (ALL)	01-04	2202379
TRX 475 FORMAN PS, EPS (FOOTSHIFT)	2009	2202898
TRX 450 FOREMAN 4X4 (ALL)	98-04	2202381
TRX 420 RANCHER (ALL)	07-12	2202889
TRX 400 RANCHER (ALL)	04-07	2202375
TRX 400 4X4	95-01	2202381
TRX 350 RANCHER (ALL)	00-06	2202375
TRX 300 2X4 / 4X4	93-00	2202352
TRX 250 RECON (ALL)	97-12	2202911
BIG RED	09-11	2202903

KAWASAKI	YEAR	SW PART #
750 BRUTE FORCE 4X4	05-12	2202881
700 PRAIRIE 4X4	04-06	2202382
650 BRUTE FORCE INDEPENDENT AXLE	2011	2202881
650 BRUTE FORCE STRAIGHT AXLE	06-09	2202899
650 BRUTE FORCE STRAIGHT AXLE	2005	2202875
KVF 650 PRAIRIE 4X4	02-03	2202382
360 PRAIRIE (ALL)	03-11	2202846
3010 MULE (4 DOOR)	09-11	2202902
4010 MULE DIESEL (2 & 4 DOOR)	05-07	2202868
KAF 550 MULE 4X4	2004	2202868
610 MULE	05-11	2202882
KAF 620 MULE 4X4	03-05	2202868
750 TERYX 4X4	08-11	2202891

POLARIS	YEAR	SW PART #
850 SPORTSMAN XP (INCLUDING TOURING)	09-11	2202900
800 SPORTSMAN 4X4	2011	2202900
800 SPORTSMAN 4X4	05-11	2202863
800 SPORTSMAN 800 X2 & TOURING TWO-UP	07-09	2202863
700 SPORTSMAN 4X4 X2 TWO-UP	2008	2202863
700 SPORTSMAN 4X4	02-07	2202863
600 SPORTSMAN 4X4	03-05	2202863
550 XP SPORTSMAN (AND TOURING X2)	09-11	2202900
500 SPORTSMAN 4X4 X2 TWO-UP	07-09	2202863
500 ATP HO 4X4	04-05	2202872
500 HO SPORTSMAN	2011	2202900
500 SPORTSMAN 4X4	04-10	2202863
500 SPORTSMAN 4X4	96-03	2202872
500 SPORTSMAN 6X6	00-08	2202872
500 MAGNUM / XPLOER 4X4	97-00	2202872
455 DIESEL 4X4	99-00	2202872
450 SPORTSMAN 4X4	06-07	2202863
425 XPEDITION 4X4	2000	2202872
400 SPORTSMAN 4X4	04-05	2202863
400 SPORTSMAN 4X4	01-03	2202872
400 XPLOER 4X4	95-02	2202872
335 SPORTSMAN 4X4	98-00	2202872
330 ATP 4X4	04-05	2202872
325/330 MAGNUM 4X4	00-04	2202872
300 SPORTSMAN 4X4	08-10	2202912
300 HAWKEYE	06-07	2202912
RANGER RZR 900	2011	2202914
RANGER RZR 800 RZR-S	08-11	2202890
RANGER 500, 700, 6X6	03-09	2202871
RANGER 500 ('09), 700 XP ('09), 800 ('10)	09-10	2202894
RANGER 500 (ALL)	11-12	2202915
RANGER 400	10-11	2202915

SUZUKI	YEAR	SW PART #
750 KING QUAD	08-11	2202874
700 TWIN PEAKS	04-05	2202382
700 KING QUAD	05-07	2202874
500 VINSON 4X4 (ALL)	02-07	2202387
500 KING QUAD	09-11	2202874
450 KING QUAD	07-09	2202874
400 KING QUAD	08-11	2202895
400 EIGER (ALL)	02-07	2202387
620 4X4 Q.U.V.	2005	2202868

YAMAHA	YEAR	SW PART #
700 GRIZZLY 4X4 (ALL)	07-12	2202883
660 GRIZZLY 4X4	02-08	2202383
550 GRIZZLY (ALL)	09-11	2202883
450 GRIZZLY 4X4	07-12	2202866
450 WOLVERINE 4X4	06-09	2202896
450 KODIAK 4X4	03-06	2202866
400 BIG BEAR 4X4	07-11	2202886
400 BIG BEAR 4X4	00-06	2202377
400 KODIAK 4X4	03-05	2202866
400 GRIZZLY 4X4	2007	2202866
350 GRIZZLY 4X4	07-11	2202866
350 BRUIN 350 4X4	04-06	2202866
350 WOLVERINE 2X4	06-09	2202896
350 WOLVERINE 4X4	95-05	2202365
RHINO 700	08-12	2202908
RHINO 660	04-07	2202908
RHINO 450	06-09	2202908



Superwinch's Jeep Mount Plate for the, CJ, YJ, and TJ models are what every Jeep owner has been waiting for. They are easy to mount for the do-it-yourself enthusiast and add rugged support so you can tackle the toughest terrain.

- Fits EP Series up 9,000 lbs (4082 kg)
- Talon Series up to 12,500 lbs (5670 kg)
- Tiger Shark up to 11,500 lbs (5216)
- LP Series, X9, and S9000



(WINCH NOT INCLUDED)

### TJ Jeep Mount Plate

P/N 2302290 - Fits EPi9.0S, Rock 98, EP6.0, EP9.0, EPi6.0, EPi9.0 and Talon 9.5 and 12.5 winch models

Designed to attach directly to TJ frame rails to ensure adequate support for winching activities. Unique design provides adequate clearance above stabilizer bar. Made of 1/4" steel with black power coat finish to resist corrosion. Includes mounting hardware.

(Note: Not For UK / EU Manufactured Vehicles)



2302290 TJ

### YJ Jeep Mount Plate

P/N 2302289 - Designed to attach directly to YJ frame rails to ensure adequate support for winching activities. Made of 1/4" steel with black power coat finish to resist corrosion. Includes mounting hardware.

(Note: Not For UK / EU Manufactured Vehicles)



2302289 YJ

### CJ Jeep Mount Plate

P/N 2302288 - Designed to attach directly to CJ frame rails to ensure adequate support for winching activities. Made of 1/4" steel with black power coat finish to resist corrosion. Standard 4.5" x 10" winch bolt pattern. Includes mounting hardware.

(Note: Not For UK / EU Manufactured Vehicles)



2302288 CJ

### Universal Winch Mount Plate

P/N 1665 - Fits EP9.0, EPi9.0, X9, S9000 (UK / EU PN 258001 Fits EP9.0, EPi9.0)



1665 UNIVERSAL

### Talon Mounting Plate

P/N 216001 - Fits Talon 14 and 18  
P/N 258001 - Fits Talon 9.5 and 12.5 (UK / EU only)



216001 Talon

### EP Mount Plate

P/N 2302287 - Fits EP12.5, EP16.5  
P/N 258006 - (UK / EU) Fits EP12.5 and EP16.5



2302287 EP

### LP Winch Mount Plate

P/N 2302292 - Fits LP8500 and LP10000 winch models  
P/N 2302294 - Fits LP8500 (Mount Plate & Roller Fairlead)



2302292 LP





- #1 Find your vehicle
- #2 Choose your Grill Guard with a winch plate for up to 9,500lbs Superwinch or up to 16,000 lbs Superwinch.
- #3 Add optional Brush Guard for full front end protection.

Model			Grill Guard w/ 9.5 Winch Mount	Grill Guard w/ 16.5 Winch Mount	Notes	Optional Brush Guard Module
<b>Toyota</b>						
Tundra	2007	2009	65608A	65608B		65608C
Tundra	2010	2012	65609A	65609B	Will not fit EcoBoost	65608C
<b>Nissan</b>						
Pathfinder	2005	2012	65610A			
<b>Ford</b>						
Expedition	2010	2012	65619A	65619B	4x4 Model	
F-150 (Will not fit Harley or FX2)	2006	2008	65637A	65637B	Will not fit FX2	65637C
F-150	2009	2012	65639A	65639B	Will not fit EcoBoost or Harley Davidson Models	65639C
Super Duty F-250	1999	2004	65640A	65640B	Will not fit 4WD or Harley Davidson Models	
Super Duty F-350	1999	2004	65640A	65640B	Will not fit 4WD or Harley Davidson Models	
Super Duty F-450	1999	2004	65640A	65640B	Will not fit 4WD or Harley Davidson Models	
Super Duty F-550	1999	2004	65640A	65640B	Will not fit 4WD or Harley Davidson Models	
Excursion	2000	2004	65640A	65640B	Will not fit 4WD or Harley Davidson Models	
Super Duty F-250	2005	2007	65641A	65641B	Will not fit Harley Davidson Models	65641C
Super Duty F-350	2005	2007	65641A	65641B	Will not fit Harley Davidson Models	65641C
Super Duty F-450	2005	2007	65641A	65641B	Will not fit Harley Davidson Models	65641C
Super Duty F-550	2005	2007	65641A	65641B	Will not fit Harley Davidson Models	65641C
Super Duty F-250	2008	2010	65642A	65642B	Will not fit Harley Davidson Models	65642C
Super Duty F-350	2008	2010	65642A	65642B	Will not fit Harley Davidson Models	65642C
Super Duty F-450	2008	2010	65642A	65642B	Will not fit Harley Davidson Models	65642C
Super Duty F-550	2008	2010	65642A	65642B	Will not fit Harley Davidson Models	65642C
Super Duty F-250	2011	2012	65644A	65644B		65644C
Super Duty F-350	2011	2012	65644A	65644B		65644C
Super Duty F-450	2011	2012	65644A	65644B		65644C
Super Duty F-550	2011	2012	65644A	65644B		65644C
<b>Dodge</b>						
Durango	2006	2008	65652A	65652B		65652C
Ram 2500	2003	2009	65663A	65663B	Will not fit Ram Sport or Plastic Bumpers	65663C
Ram 3500	2003	2009	65663A	65663B	Will not fit Ram Sport or Plastic Bumpers	65663C
Ram 3500 Cab & Chassis	2010	2012	65663A			65663C
Ram 4500	2008	2012	65665A	65665B		65663C
Ram 5500	2008	2012	65665A	65665B		65663C
Ram 1500	2009	2012	65666A	65666B	Will not fit Ram Sport or Plastic Bumpers	
Ram 2500	2010	2012	65669A	65669B		65669C
Ram 3500	2010	2012	65669A	65669B		65669C
Ram 1500	2013	2013	65671A	65671B	Will not fit Ram Sport or Plastic Bumpers	
<b>Chevrolet</b>						
Silverado Classic 1500	2003	2007	65731A	65731B		65731C
Avalanche without factory cladding	2003	2006	65731A	65731B	without factory cladding	65731C
Silverado/Classic 2500 HD	2003	2007	65732A	65732B		65732C
Silverado/Classic 3500	2003	2007	65732A	65732B		65732C
Silverado 1500	2007	2012	65735A	65735B		65735C
Silverado 2500HD	2007	2010	65738A	65738B	Will not fit Denali or Denali style grilles	65738C
Silverado 3500	2007	2010	65738A	65738B	Will not fit Denali or Denali style grilles	65738C
Silverado 2500HD	2011	2012	65751A	65751B		65751C
Silverado 3500	2011	2012	65751A	65751B		65751C
<b>GMC</b>						
Sierra 2500HD	2007	2010	65738A	65738B	Will not fit Denali or Denali style grilles	
Sierra 3500	2007	2010	65738A	65738B	Will not fit Denali or Denali style grilles	
Sierra 1500	2007	2012	65745A	65745B	Will not fit Denali or Denali style grilles	
Sierra 2500HD	2011	2012	65751A	65751B		
Sierra 3500	2011	2012	65751A	65751B		



**P/N 06720 (06721 EU frequency)**

For use with 12VDC / 24VDC  
**Superwinch Power Drive Units.**



**P/N 06722 (06723 EU frequency)**

For use with 12VDC / 24VDC  
**Superwinch Industrial Units.**

**P/N 06714 (06715 EU Frequency)**



For use with 12VDC / 24VDC  
**Superwinch Talon Series**

System plugs directly into Talon solenoid box.



**P/N 06716 (06717 EU Frequency)**



For use with 12VDC / 24VDC  
**Superwinch Terra Series**

System wires directly onto Terra solenoid.



**P/N 06718 (06719 EU Frequency)**



For use with 12VDC / 24VDC  
**Superwinch S Series (Trailer Winches)**  
(fits only 7 pin connector)

System plugs directly into S Series, X9, S9000, Husky and EP SERIES



(Winch not included)



# ROAM™ Networked System

Winch Control & Monitoring App via your Smart Phone



ROAM™ by Superwinch, an interactive smartphone application, heralds a new era in winching. The system provides not only full control but puts crucial winch data at the user's fingertips.

- Monitor in **REALTIME**:
- WiFi™ In and Out, remote control indicator
  - Winching, Battery Amp Draw
  - Winch Motor Temperature
  - Rope Line Speed
  - Run Time, Event Duration Data
  - Instant personal contact communication



**ROAM™**  
by SUPERWINCH®

SUPERWINCH



**CERTUS™** WIRELESS SYSTEMS



- Superwinch's Certus™ Wireless Remote System enables wireless winch operation from up to 60 feet away
- "Plug & Play" for Talon, Terra and S Series, Quick installation
- Superior FM Signal - Choose from 4 models or power drive
- Transmitter & Receiver meets IP67 standard
- Transmitter Floats in water
  - USA Model Operates on 915 MHz - 12v or 24v
  - EU Model Operates on 868 MHz - 12v or 24v
- All are FCC and IC approved

CE



SUPERWINCH



(Winch not included)



**BOW SHACKLES**



2538 Heavy-duty steel large capacity



2302285 ATV Heavy-duty steel shackles

**WINCH ROPE DAMPENER**



2570

**PULLEY BLOCKS**

2227A 8,000 lbs Pulley Block Use winches up to 4,000 lbs

2229A 10,000 lbs Pulley Block Use on winches up to 5,000 lbs

2212A 12,000 lbs Pulley Block Use on winches up to 6,000 lbs

7750A 20,000 lbs Heavy Pulley Block Use on winches up to 10,000 lbs

7754 11,000 lbs Pulley Block Use on winches up to 5,500 lbs



7755 36,000 lbs Heavy Duty Pulley Block Use on winches up to 18,000 lbs

**SMALL ACCESSORY KIT**



1554 10,000 lbs Nylon Sling Pulley Block, Nylon Carry Bag, Heavy Duty Leather Palmed Gloves

**LARGE ACCESSORY KIT**



2224 20,000 lbs Nylon Carry Bag, Pulley Block, Heavy Duty Leather Palmed Gloves

**ATV ACCESSORY KIT**



2302286 1 Bow Shackle 1" x 8' Tree-saver Strap Carry Bag Heavy Duty Palmed Gloves

**RECOVERY STRAPS**

2517 2" x 20' strap; 15,600 lbs  
2518 2" x 30' strap; 15,600 lbs  
1059 2" x 6' strap; 15,600 lbs  
2531 3" x 8' strap; 23,500 lbs  
2302284 1" x 8' ATV strap; 8,000 lbs  
Rated at ultimate strength.  
(Not available in UK or EU)



**CHAINS with GRAB HOOKS**



2541 10' X 3/8" Chain (Not available in UK or EU)

**SYNTHETIC ROPE**

87-42613 50' 3/16" Dyneema® Synthetic Rope fits Terra 25 / Terra 35 winch

87-42614 50' 1/4" Dyneema® Synthetic Rope fits Terra 45 winch

89-20521 40' 1/4" Synthetic Rope fits Danny O'Day S Series winch

90-24510 50' 3/8" Synthetic Rope fits, Rock 98/12.8 winch

90-24506 80' 3/8" Synthetic Rope fits, Talon, 9.5,12.5 and BILL BURKE HUSKY 10

90-24564 1/2"x 90' Talon 14 and 18 winches

**SOLENOID - S3**

90-14452 12VDC  
90-14454 24VDC Fits, EP Series S-9000 and Husky 10 (USA)

**SOLENOID - Single Pack**

2237 Fits 12VDC X3, X6, X9 and S-6000



**Roller Fairleads**

2549 Fits X6, X9, S6000 and S9000 winches 11" x 3 3/4"

1560A Fits EX1, X1, X2, X3 winches

1560C Fits all GP and T series winches

2235 Fits S Series winches 5 1/4" x 3 1/4"

2302293 Fits LP8500 and LP10000

90-32493 Fits Tiger Shark 9500/11500

90-32505 Fits Tiger Shark 13000/15500/17500

8584 Fits all Husky winches

90-32473 Fits Talon, 9,500 / 12,500 / 14,000 and 18,000 lbs winches

**Hawse Fairleads**

90-24507 Aluminium Hawse Fairlead for Talon

90-24509 Aluminium Hawse Fairlead for Rock 98

87-42619 Aluminium Hawse Fairlead for Terra 25 / Terra 35

87-42620 Aluminium Hawse Fairlead for Terra 45

90-12865 Steel Hawse Fairlead for LP8500

**Replacement Wire Rope**

For all winch models, only from Superwinch! Quality galvanized steel wire rope to resist corrosion and includes thimble steel channel that holds wire rope in a wide curve, protecting it from wear.

**Wire rope sizes**

P/N	Wire Rope Length/Diameter	Winch Model
90-33473	7/16"x 90' (11.1mm x 27.4m)	EP16.5
90-33472	3/8"x 125' (9.5mm x 38.1m)	EP12.5, EP9.0
90-20506	21/64"x 100' (8.3mm x 30.5m)	EP6.0, EP9.0
90-20515	21/64"x 125' (8.3mm x 38.1m)	EP6.0, EP9.0
2537	3/8"x 90' (9.5mm x 27.4m)	Husky 10
2562	5/16"x 150' (7.9mm x 45.7m)	Husky 8.5
1580	5/16"x 100' (7.9mm x 30.5m)	X6, X9
90-12870	5/16"x 94' (7.9mm x 29.0m)	LP8500
1577A	1/4"x 50' (6.4mm x 15.2m)	S5000
1514A	7/32"x 60' (5.6mm x 18.2m)	S4000
1511C	3/16"x 60' (4.8mm x 18.2m)	S3000, WIAB
1511F	3/16"x 50' (4.8mm x 15.2m)	GP3000, WIAB, PLUS, UT3000, Terra 25, LT3000, ATV
1535D	5/32"x 60' (3.9mm x 18.2m)	GP2300
87-19019	3/16"x 50' (4.8mm x 15.2m)	ATV3000, ATV2500
87-19039	7/32"x 50' (5.5mm x 15.2m)	UTV4000
1513	7/32"x 40' (5.6mm x 12.2m)	X2
1511	7/32"x 40' (5.6mm x 7.5m)	X1
1535	5/32"x 25' (3.9mm x 7.6m)	EX1
1535C	5/32"x 50' (3.9mm x 15.2m)	T2000, LT2000
87-42611	7/32"x 50' (5.5mm x 15.2m)	Terra 35
87-42612	1/4"x 55' (6.2mm x 16.76m)	Terra 45
90-12879	3/8"x 85' (9.5mm x 26m)	LP10000
90-24550	3/8"x 85' (9.5mm x 26m)	Talon 9.5, 12.5
90-24563	1/2"x 90' (13mm x 27.43m)	Talon 14, 18
90-24584	13/32"x 95' (10.3mm x 29m)	Tiger Shark 13500
90-24585	29/64"x 92' (11.5mm x 28m)	Tiger Shark 15500
90-24586	1/2"x 90' (12.7mm x 27.4m)	Tiger Shark 17500
90-24575	21/64"x 95' (8.3mm x 29m)	Tiger Shark 9500
90-24576	3/8"x 84' (9.5mm x 26m)	Tiger Shark 11500

**Heavy Duty Hooks**



90-24511 Latched Half-Link Hook For Synthetic Rope, fits Rock 98/12.8



90-24567 Latched Half-Link Hook for Synthetic Rope Talon, 14.0SR and 18.0SR

**Clevis Hooks**

90-20435 Latched Clevis Hook for X9, S9000, Danny O'day winch

90-24577 3/8" Latched clevis hook for Tiger Shark 9500/11500

90-24587 1/2" Latched clevis hook for Tiger Shark 13500/15500, Talon 9.5SR/9.5iSR/12.5SR/12.5iSR 14.0/18.0



**U.K., Wire rope sizes**

P/N	Wire Rope Length/Diameter	Winch Model
90-0563S	(10mm x 30m)	Husky 10
419S	(9mm x 23m)	Husky 8
200007S	(9mm x 23m)	Husky 8
20009	(11mm x 26m)	EP16.5
200005	(8mm x 30m)	X6, X9



Switches & Remotes Quick Connects



2233B  
Rocker Switch  
Fits T2000



1519A  
Repair Switch with  
3 ft. wire Pigtail fits  
T1500, S and X Series  
with direct switches



1501B  
Dash Mount Kit fits  
all X Series, EX1, X1  
and X2 Series winches



1591  
Three position heavy  
duty rotary switch for  
remote switching of  
EX1 - X2F Power Drives



2270  
15' Handheld Switch



2271  
30' Handheld Switch



90-32471  
Talon Ergo Handheld Switch



90-32484  
Talon Rubber Handheld Switch



90-12864  
Rubber coated handheld with toggle  
switch and 15' cord LP8500, LP10000,  
UT3000



1551  
Fits winches  
up to 4,000 lbs

2236  
Fits winches up to 18,000 lbs

Wiring Kits



1520  
Trailer Wiring Kit Fits -  
EX1, X1, X2, X3, S3000  
and S4000 winches



2008  
Trailer Wiring Kit Fits -  
5000 to 18,000 lbs winches with 25 Lead



2007  
Front Wiring Kit - Fits 5,000 to  
18,000 lbs winches with 5' Lead

SUPERTEAM <SUPERTEAM@Superwinch.com>



87-12869  
Fits: LT2000 Winch



2302283  
**SHORT** Solenoid Relocation Kit  
allows you to relocate solenoid  
or solenoid control pack



2302282  
**LONG** Solenoid Relocation  
Kit allows you to relocate  
the solenoid or  
solenoid control pack

Receiver Shackle  
Bracket



2546  
Fits all Standard  
Class III  
Receiver Hitches

Portable Winch  
Mounts



1559B  
2" CLASS III Receiver  
Hitch Mount



2060  
Ball Hitch Mount  
Fits: LT2000  
S Series  
GP Series



2055  
Small 2 bolt pattern  
Cradle Hitch Mount



Fits: X3  
S5000  
S4000  
S3000



2050  
Large 4 bolt pattern  
Cradle Hitch Mount  
Fits: All Winches  
with 10" x 4.5"  
hole pattern,  
up to 9,500 lbs



VINYL WINCH  
COVERS



1504  
Fits EX1, X1 and X2 winches



1505  
Fits X3, X3F, S3000, S4000 and S5000  
winches



1566  
Fits X6, X9 and Husky winches

NEOPRENE WINCH  
COVERS



2302306  
Fits EP 6 and EP 9



1570  
Talon 9.5, Rock 98, 12.5 and Tiger  
Shark 9500, 11500 winches, LP Series



1571  
Talon 9.5i, and 12.5i and S9000 winches



1572  
Talon 14.0 and 18.0 and Tiger Shark  
13500, 15500, 17500 winches

Superwinch® T-SHIRTS



00340  
Small - Black Superwinch T-Shirt

00341  
Medium - Black Superwinch T-Shirt

00342  
Large - Black Superwinch T-Shirt

00343 - Black Superwinch T-Shirt  
X Large - Black Superwinch T-Shirt

00344 - Black Superwinch T-Shirt  
XX Large - Black Superwinch T-Shirt

00345 - Black Superwinch T-Shirt  
XXX Large - Black Superwinch T-Shirt

Superwinch®  
HEAVY DUTY GLOVES



90-22611

Superwinch® HATS  
00335A



Superwinch®  
HOODIES



HAND SAVERS



87-31120 / 2239

90-32472

Superwinch®  
STICKERS

- 00320 White small 9"x 1.5"  
(228.6 x 38.1)mm
- 00321 Blue small 9"x 1.5"  
(228.6 x 38.1)mm
- 00322 White medium 14.5"x 2.25"  
(368 x 57.15)mm
- 00323 Blue medium 14.5"x 2.25"  
(368 x 57.15)mm
- 00324 White large 24.5"x 3.75"  
(622.3 x 95.25)mm
- 00325 Blue large 24.5"x 3.75"  
(622.3 x 95.25)mm
- 00326 White extra large 37"x5"  
(939.8 x 127)mm
- 00327 Blue extra large 37"x5"  
(939.8 x 127)mm



ATV UTILITY UPGRADE  
SWITCH KIT



2320200  
Fits: LT2000

ATV UTILITY UPGRADE  
ACCESSORY KIT



23022001  
Fits: LT2000



# PREMIUM HUBS



Made in Brazil

**Superwinch Premium Hub Advantage.** Easy and quick engagement and disengagement. Always positive engagement, robust coil springs for reliability. All metal construction sealed to keep contaminants out. Fits most popular vehicles.

### CHEVROLET / GMC / GEO

Make/Model	Year	Count	Hub #	Notes
Blazer/Jimmy/Surburban	69-91	19 - Internal	400518	A
1/2 Ton Pickup	69-87	19 - Internal	400518	A
3/4 Ton Pickup	77-87	19 - Internal	400518	A
1 Ton Pickup	76-91	30 - Internal	400439	A
Geo Tracker	All	26 - 6	400538	

\*All 1988 Chevrolet pickups are equipped with an automatic system which cannot be converted.

### DODGE / CHRYSLER

1/2 Ton Pickup & Ramcharger	69-75	19 - Internal	404518
1/2, 3/4 Ton Pickup & Ramcharger	80-93	19 - Internal	404518
3/4 Ton Pickup	90-93	30 - Internal	400439
1 Ton Pickup (Dana 60)	90-93	30 - Internal	400439

### Ford

Bronco (not Bronco II)	66-96	19 - Internal	400518	A, C
1/2 Ton F100 Pickup	59-86	19 - Internal	400518	A
1/2 Ton F150 Pickup	59-96	19 - Internal	400518	A, C
3/4 Ton F250 Pickup (D-44)	59-75	19 - Internal	400518	A
3/4 Ton F250 Pickup (D-44)	78-86	19 - Internal	400518	A
3/4 Ton F250 Pickup (D-60)	78-97	30 - Internal	400439	A, C
1 Ton F350 Pickup	76-97	30 - Internal	400439	A, C
Super Duty F 250 & F 350	00-04	30 - Internal	400439	A
Ranger	90-97	27	400565	E
Explorer	90-94	27	400565	E

### International-Harvester

1/2 Ton Pickup	68-75	19 - Internal	400518
Travel All	68-75	19 - Internal	400518

### Isuzu

Trooper II	87-86	17 - 6	400533	D
AMIGO	87-99	17 - 6	400533	D
Rodeo	91-99	17 - 6	400533	D

### JEEP

CJ, Universal	81-86	27 - 5	400526	
J-10 Pickup	74-90	19 - Internal	400518	B
J-30 Pickup	77-90	19 - Internal	400518	B
WAGONEER, Cherokee, Gladiator	74-90	19 - Internal	400518	B

### Suzuki/Geo

Samurai, Sierra	82-94	26 - 6	400538
Sidekick/Tracker All	All	26 - 6	400538

Parts  
334401-06 10/32 Tapered Bolt Qty. 6

#### CAUTIONARY FOOT NOTES:

- A. When replacing Fulltime 4WD, (the NP203 only), requires a conversion kit (see chart).
- B. Not compatible with Quatra Trac equipped models.
- C. When replacing automatic 3 hole cap screw hubs, one will need to convert their spindle nuts.
- D. One must obtain special snap ring (26 mm or 1 1/16), (Dealer item).
- E. When replacing automatic hubs with manual hubs, one must also change the spindle nuts.



PN: 400565



PN: 400518



# SUPERWINCH

Designed, Engineered, Tested & Built by Superwinch®



Danny O' Day is no stranger to racing. Recognized, as the "Worlds Fastest Man on two wheels", attaining the quarter mile in 8.50 seconds, that's over 155 mph! Danny has been sponsored by SUPERWINCH for many years. In fact he sought SUPERWINCH out. "We use the best stuff in our race car Superwinch is a perfect match for that. Whichever trailer you are loading, there's a SUPERWINCH designed to deliver the power that meets your needs."



**Danny O'Day and Donna O'Day, Ashe County, NC 38632 / visit: [www.superwinch.com](http://www.superwinch.com) for race schedule.**

Bill Burke is a professional guide, an internationally recognized trainer who teaches back country driving techniques, winching/extraction methods, vehicle preparation and maintenance, land navigation and woods' skills through classes, private training, trainer and trail leader courses, and back country trips to individuals, families, groups, clubs, vehicle manufacturers/dealers, tour operators, government agencies and all companies that use 4WD vehicles in their operations. Here is what Bill has to say about Superwinch: "I was introduced to the Superwinch line over 25 years ago during my involvement with the Camel Trophy. I recognized a quality industrial grade that could reliably withstand constant use and abuse. I trust Superwinch to get me unstuck regularly, as a guide and 4WD trainer 24/7-365 in all weather conditions, roughest rocks and in the most inhospitable areas. The VS4 solenoid works every time, the 100% load holding brake keeps my rig steady on the steepest inclines and the strong gearing and drum mechanism never failed to give me the confidence to use the winch in properly rigged situations World-wide. In my opinion Superwinch is the most recovery reliable and sturdy winch available.

Thanks for making such a great product.  
Bill Burke

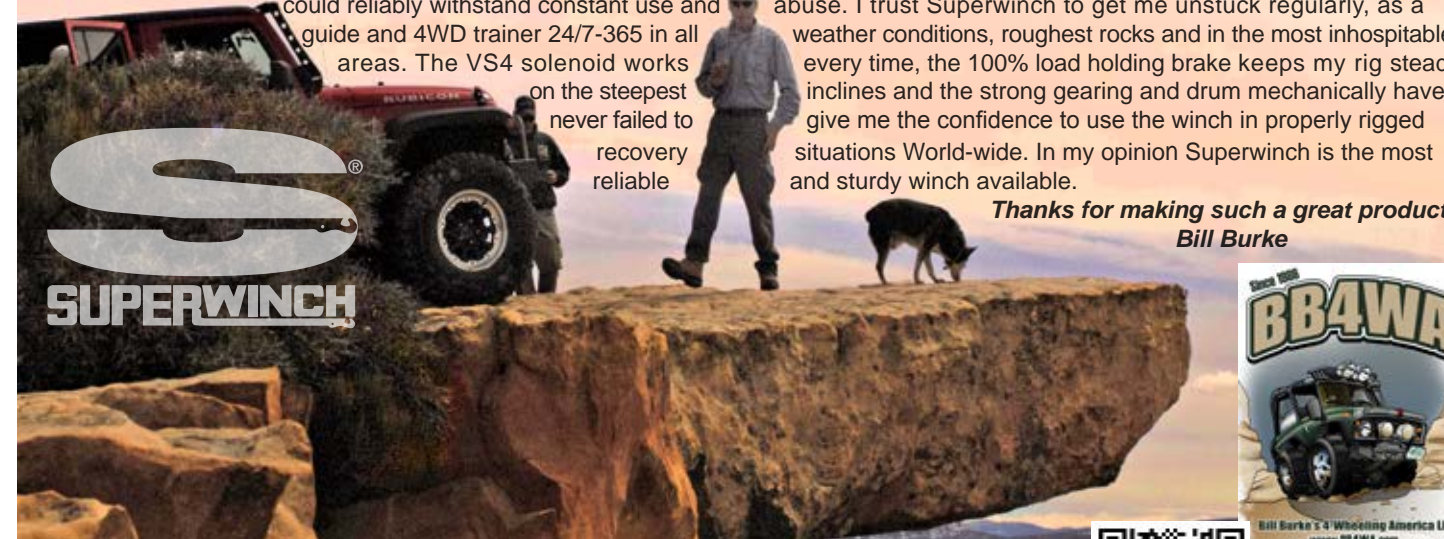

Find out more about Bill and his opinions on winches and winching at [www.bb4wa.com](http://www.bb4wa.com) / <https://www.facebook.com/4WheelingAmerica>





# SUPERWINCH®

Designed, Engineered, Tested & Built by Superwinch®

Lead by Bruce Elfstrom, Overland Experts LLC (OEX) has become a world-class training organization in the science and art of off-roading. Catering to the professional, recreational and military markets, Bruce Elfstrom knows off-roading – he’s been driving since he was 7. He’s navigated his way across four continents and has hundreds of OEX graduates in the field. Here’s an excerpt on what Bruce has to say about winch basics:

In order to even contemplate using a winch, you will need several accessories. A fairly well-supplied winching bag includes the following: proper gloves; three D-shackles (9,500-17,000-pound working load or WL); three 3-inch straps (20,000 pound WL), three 5/16 inch pulley blocks (19,250 pounds WL) and one 50-foot 3/8 inch synthetic rope extension (19,700 lbs WL). I prefer to use synthetic rope, which is stronger per unit measurement and lighter to carry. Synthetic rope does not burr or rust. It has less mass, and therefore holds less energy when it parts—less energy equals less damage. However, synthetic rope insulates the spool of the winch, compared to metal which conducts heat way from the spool. Winches that have the brake in the spool, or are designed to dissipate heat at the spool, can heat up dramatically with synthetic rope. The heat will compromise the winch and the rope at the same time.” –Overland Journal, Spring 2009 Bruce’s input on brake design keeps Superwinch ahead of the pack. Our synthetic rope winches feature both a brake away from the drum and an upgraded drum that can handle the added stress synthetic ropes generate. Superwinch is proud to partner with OEX.

Learn more about OEX and Bruce Elfstrom at [www.overlandexperts.com](http://www.overlandexperts.com), Telephone: (860) 873-9640



Barlow Jeep School was established in 2010 to offer cost effective group courses, expanding on the private 4x4 training consultation business. Founder, Owner, and head guide, Nena Barlow, is a 4x4 trainer certified by International 4wd Trainer Association; she has owned and/or operated various 4-wheel-drive businesses since 1993 including JeepTrailInfo.com, Sedona Jeep School, Barlow Jeep Rentals, and various 4x4 tour companies. Barlow is joined by veteran instructors Darryl Ranges and Joey Steiner, as well as a seasoned crew of 4-wheelers as support crew and staff.

The Superwinch Team met Nena on the trail in Moab several years ago and recognized her off-road knowledge and driving abilities were the perfect match for a Southwest based real world winch test lab! Nena’s vehicles punish our winches everyday on the trails all over Arizona, Colorado, Utah and California.



Barlow Jeep School helps off-highway drivers achieve fundamental four-wheeling skills through hands-on experience, with the emphasis on safety, responsible 4-wheel drive practices, and ethical land use. Clients gain an awareness of the principles of 4x4 driving, and learn about the available resources for continuing to build skills and knowledge. This way, experience may be gained in a safe and fun manner, rather than by costly trial and error.



Whether you are brand new to off-pavement driving or an experienced four-wheeler looking to hone your 4x4 driving skills with an expert on-hand, Barlow Jeep School provides a step-by-step course for trail analysis and driving techniques. A good grasp of the fundamentals of vehicle dynamics and traction principles benefits all levels of off-road drivers.

For more information call (928) 282-8700 or go to [www.barlowjeepschool.com](http://www.barlowjeepschool.com)



Barlow Jeep Rentals Facebook

# SUPERWINCH®

Designed, Engineered, Tested & Built by Superwinch®

## SUPERWINCH® 2014 SPONSOR

Jeep® Jamborees are off-road adventure weekends that bring together the outdoor, down-to-earth people, and their Jeep 4x4s. These off-road treks have a long tradition dating 1953 when 4x4 pioneer Mark A. Smith organized the first ever Jeep Jamboree and voyaged across the Sierra Nevada Mountains by way of the old Rubicon Trail. In 1954, Willys Motor - then manufacturer of Jeep vehicles - became involved with the adventure, and Jeep Jamborees have been an on-road tradition ever since.

A member of off-road Hall of Fame and the Explorers Club, Mark A. Smith also led the 1978/79 Expeditions de las America crossing - a 20,000 mile odyssey from the lower region of South America to the top region of North America, crossing the infamous “Darian Gap” and headed the 1987, Camel Trophy, in Madagascar. Since founding Jeep Jamboree USA in 1982 he’s become a Jeep brand consultant and conducts intensive training for the U.S. Army Special Forces and various law-enforcement agencies. The Smith’s Jeep Jamboree USA conducts over 30 family-oriented Jeep 4x4 trips nationwide and truly a family business. Daughter Jill, President and CEO, brings camaraderie and excitement to thousands of Jeep 4x4 owners annually. Son in law Pearse Umlauf, Vice President and General Manager, is focused on expanding Jeep Jamboree USA, which is the Worlds largest Jeep adventure company.

[www.jeeptamboreeusa.com](http://www.jeeptamboreeusa.com)  
Jeep Jamboree USA, 2776 Southdough Flat, Georgetown, CA 95634

530 333-4777 (phone) / 530 333-2844 (fax) Office hours 9 a.m. to 5 a.m. Pacific Time Zone (Monday - Friday)

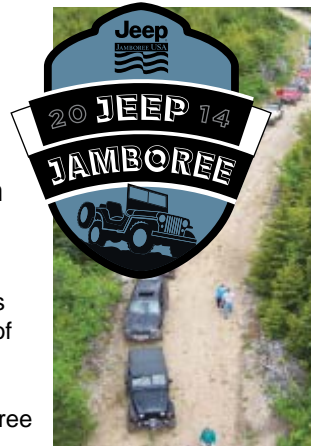

Outlaw Jeep Tours and Rentals Moab, UT. set themselves apart from any other Jeep company in Moab. By offering Rentals, Ride Along, Guided Tours, RZR Rentals, Repair, and Recovery, and they have become the most accommodating One Stop Jeep Shop around. Own your own 4x4 but not familiar with the trails in Moab or your vehicle’s capability? We offer a “follow us” guided tour through any trail Moab offers, from scenic family fun trips to hard core rock crawling. Outlaw is Superwinch’s “Base Camp” every year during the Easter Jeep Safari Week! (435)-259-8845 Toll Free Phone: (855)-259-8845 Email: [outlawjeeptours@gmail.com](mailto:outlawjeeptours@gmail.com)



Tread Lightly! and its partners lead a national initiative to protect and enhance recreation access and opportunities by promoting outdoor ethics to heighten individuals’ sense of good stewardship. Tread Lightly!’s goal is to balance the needs of the people who enjoy outdoor recreation with our need to maintain healthy ecosystems and thriving populations of fish and wildlife. The scope of our work includes both land and water, and is representative of nearly every form of outdoor recreation including, but not limited to hunting, recreational shooting, fishing and boating. We also have a niche in promoting safe and responsible use of motorized and mechanized vehicles in the outdoors.



Superwinch has supported Tread Lightly! for over 2 decades!

Fax: (801) 990-9807 Phone: (801) 627-0077 Toll-Free: (800) 966-9900 [treadlightly.org](http://treadlightly.org)



# WARRANTIES

## The best protection in the business !

Superwinch proudly stands behind its products with the industry's best warranties. Several years ago we implemented an exclusive 3-year warranty on our robust S3 Solenoid. While most manufacturers use off-the-shelf solenoids designed for automotive use, the S3 Sealed Submersible Solenoid was designed by Superwinch engineers to outperform other solenoids on the market. We have now raised the bar with the game changing VS4 Solenoid (Vented, Submersible, and Stabilized with Sealed Socket). This is the best winch solenoid in the world and only available on the new Superwinch Talon Series. Covered by a Limited Lifetime Warranty which includes a 3-year warranty on all electrical components, the absolute BEST in the INDUSTRY!



### Limited Lifetime Warranty

Superwinch, LLC. warrants to the original retail buyer only that the mechanical components of all genuine SUPERWINCH® Winch Models shall be free from defects in materials and workmanship from the provable date of purchase of the new Product for the lifetime of the winch and the electrical components shall be free from defects in materials and workmanship for three (3) years from the provable date of purchase. Any Product that Superwinch determines to be defective will be repaired or replaced at Superwinch's sole discretion without charge to Buyer upon Buyer's compliance with these procedures. Seller or its Authorized Agent may make reasonable charges for parts and labour for repairs not covered by this Limited Warranty.



### Limited Lifetime Warranty

Superwinch, LLC., warrants to the original retail buyer only that the mechanical components of all genuine SUPERWINCH® Winch Models shall be free from defects in materials and workmanship from the provable date of purchase of the new Product for the lifetime of the winch, the electrical components shall be free from defects in materials and workmanship for one (1) year and the S<sup>3</sup> solenoid for three (3) years from the provable date of purchase. Any Product that Superwinch determines to be defective will be repaired or replaced at Superwinch's sole discretion without charge to Buyer upon Buyer's compliance with these procedures. Seller or its Authorized Agent may make reasonable charges for parts and labor for repairs not covered by this Limited Warranty.



### Limited Lifetime Warranty

Superwinch, LLC., warrants to the original retail buyer only that the mechanical components of all genuine SUPERWINCH® Winch Models shall be free from defects in materials and workmanship from the provable date of purchase of the new Product for the lifetime of the winch, the electrical components shall be free from defects in materials and workmanship for one (1) year. Any Product that Superwinch determines to be defective will be repaired or replaced at Superwinch's sole discretion without charge to Buyer upon Buyer's compliance with these procedures. Seller or its Authorized Agent may make reasonable charges for parts and labor for repairs not covered by this Limited Warranty.



### Limited Two-year Warranty

Superwinch, LLC. warrants to the original retail buyer only that mechanical components of the genuine SUPERWINCH® Winch Model shall be free from defects in materials and workmanship for (2) two years and electrical components for (1) one year from the provable date of purchase. Any Product Superwinch determines to be defective will be repaired or replaced at Superwinch's sole discretion without charge to Buyer upon Buyer's compliance with these procedures. Seller or its Authorized Agent may make reasonable charges for parts and labor for repairs not covered by this Limited Warranty.



### Limited One-year Warranty

Superwinch, LLC. warrants to the original retail buyer only that mechanical and electrical components of the genuine SUPERWINCH® Winch Model shall be free from defects in materials and workmanship for one year from the provable date of purchase. Any Product that Superwinch determines to be defective will be repaired or replaced at Superwinch's sole discretion without charge to Buyer upon Buyer's compliance with these procedures. Seller or its Authorized Agent may make reasonable charges for parts and labor for repairs not covered by this Limited Warranty.



### Limited One-year Motor ~ Three-year Gearbox Warranty

Superwinch, LLC. Power Drive products, except where noted, will carry a 3 year warranty on the Gearbox and 1 year Warranty on the motor against manufacturing defects only. This will be effective from date of sale to the end user. This warranty does not allow for abuse or overloading of the product. Superwinch will not repair or replace any part(s) under warranty that have become inoperative because of improper maintenance, eccentric loading, overloading, chemical or abrasive action, excessive heat or other abuse. Superwinch retains the right to replace or repair the units at its discretion. Superwinch will repair any parts proven to have been defective in material or workmanship under the warranty period and returned to Superwinch. Units or parts that have been altered or modified in any way without the written authorization of Superwinch will not be warranted. Superwinch shall not be responsible for incidental or consequential damages to property, loss of profits, loss of use or costs associated with the installation or removal of the product.

Inquiries: Any inquiries regarding compliance with warranties may be addressed in writing to Superwinch, LLC. or to Superwinch Ltd.

# The Superwinch Tradition.....



In 1970, Frank Tolsdorf, entrepreneur and marketing extraordinaire began manufacturing Superwinch electric winches in the Northeast corner of Connecticut, USA. The corporate philosophy was to offer the end-user the most reliable, highest performing winching products; all designed via problem solving innovation and from an organization dedicated to customer service.

The idea of becoming an electric winch manufacturer began in 1968 when Frank was an executive with Indian Head Corporation. As marketing director, his responsibilities included new product development. So, when two Ford engineers came to him with an offer to sell the patents and manufacturing rights of an electric winch, Frank analyzed the market and realized that there were exceptional opportunities in this field. On Frank's recommendation, Indian Head Corp. purchased Superwinch.

Detroit Gasket, the division which had product development responsibilities for Indian Head Corp., redesigned the winch and introduced it to the public in 1969. Frank was not totally captivated with the product and just when he recognized what corrections had to be made, Indian Head told Frank to sell the product line. Frank realized that if he owned the company, he would be able to make whatever changes he felt necessary. Frank contacted the president of the supplier of the wire rope used on Superwinch and together, they purchased the company. Superwinch originally offered a complete line of winches for the pleasure boating market. The marine line included three small electric winches known as the Little Commander, the Haulamatic which loaded boats up to 8000 lbs, and a powered capstan called the Windlass.

A great many things changed for Superwinch over the next 15 years including the development of satellite TV dish positioning systems. Ian Dodds, an aerospace engineer, joined Frank Tolsdorf in 1984 and collectively they continued to bring innovation and quality to the winch industry.

Superwinch purchased the New England based Mercury Electric Winch and FW Winches Limited located in Tavistock, UK (formerly Fairey Winches) providing additional manufacturing capabilities including a wide range of winches covering mechanical, hydraulic and electric drive and capstan/drum configurations. Fairey was also manufacturing an overdrive transfer gearbox for the Toyota Land Cruiser, a capstan winch for the Land Rover 110 and a mechanical overdrive unit for Land Rovers. This facility (now know as Superwinch Ltd) is still manufacturing and distributing a wide range of hydraulic worm gear and hydraulic planetary gear winches as well as the famous Husky electric worm gear winch best know for its robust performance in the Camel Trophy Series.

Over four million winches later, today's global Superwinch team lead by President & CEO Ned Cunningham is as dedicated as ever to building on that philosophy with the introduction of the Entry Level LT/LP/UT Series, the Terra ATV/UTV Series, the game changing Talon Series and now the Tiger Shark Series.

Superwinch's global manufacturing facilities have grown to design and produce a broad range of winches; from electric 12, 24 and 115 volt planetary gear, right angle gear and worm gear units to hefty hydraulic workhorses. Our 1,000 to 45,000 pound capacity winches can be found in diverse industries and applications around the world.

No resting on laurels at Superwinch. Our "Get Serious" campaign means just that; we are serious about continuous improvements, innovative design and timely market response to keep Superwinch, our OE and distribution partners and the winch end user on top. We provide the greatest value proposition in the global winch industry; innovation, function, quality, price and service. *That is the Superwinch tradition.*

Designed, Engineered, Tested and Built by SUPERWINCH®



# get serious

## SUPERWINCH



[www.superwinch.com](http://www.superwinch.com)



Tel: 1.800.323.2031



## Superwinch, LLC

359 Lake Road  
Dayville, CT USA 06241  
Tel: 1.800.323.2031  
Fax: 1.860.963.0811  
[sales@superwinch.com](mailto:sales@superwinch.com)  
[www.superwinch.com](http://www.superwinch.com)

## Superwinch, Ltd

Union Mine Road  
Pitts Cleave  
Tavistock Devon, England  
PL19 0NS  
Tel: +44 (0) 1822 614101  
Fax: +44 (0) 1822 615204  
[sales@superwinch.net](mailto:sales@superwinch.net)  
[www.superwinch.com](http://www.superwinch.com)



Tel: +44 (0) 1822 614101



Superwinch LLC. Dayville, CT USA

Superwinch LTD - Tavistock, UK

